SBC21/NSD21/EC21 Series Hardware User Manual



Release Notes

Version	Release Date	Notes
1.20	October 1 st , 2013	The 2nd release to customer
1.30	October 30 th , 2013	Add more interfaces info

Disclaimer

This documentation is provided for use with IC Nexus products. No license to IC Nexus property rights is granted. IC Nexus assumes no liability and provides no warranty either expressed or implied relating to the usage or intellectual property right infringement that may result from its use.

IC Nexus provides this document “as is,” without warranty of any kind, expressed or implied, including, but not limited to, its particular purpose. IC Nexus may make changes to this document without notice.

Table of Contents

TABLE OF CONTENTS	3
1 PRECAUTIONS	5
1.1 Safety Precautions	5
1.2 Write Prohibited Regions	6
1.3 Warranty	6
2 PRODUCT FEATURES	7
2.1 Overview	7
2.2 Features and Specifications	8
3 INTERFACE SPEC - I (EC21/NSD21/SBC21)	10
3.1 HDMI Connector	12
3.2 MicroSD Connector.....	13
3.3 UART Connectors & Debug Port	14
3.4 USB Connectors	17
3.5 Audio Interface	19
3.6 Ethernet Interface	20
3.7 Power Supply (DC-IN connector)	21
3.8 GPIO Pin Header	22
3.9 I ² C Interface	24
3.10 CAN Bus Interface	25
3.11 BM Connector	26
4 INTERFACE SPEC - II (NSD21/SBC21 ONLY)	27
4.1 Parallel Display Interface	29
4.2 LVDS Display Interface.....	31
4.3 Touch Screen Interface.....	33
4.4 Power Output Connector	34
4.5 Camera Sensor Interface.....	35
4.6 MIPI Interface	36
4.7 Expansion Connector	37
4.8 Keypad Connector	38
4.9 Mini-PCIe Connector.....	39
4.10 SATA Interface	40

5 SBC2100 PCB OUTLINE DRAWING..... 41

APPENDIX A: BOX HEADER TO DB9 CABLE..... 43

APPENDIX B: 7-INCH LCD BRIEF (WVGA)..... 44

APPENDIX C: 7-INCH LCD BRIEF (WSVGA)..... 46

APPENDIX D: 10.1-INCH LCD BRIEF 48

APPENDIX E: 15-INCH LCD BRIEF 49

APPENDIX F: 15-INCH LCD BRIEF (HIGH BRIGHTNESS) 51

APPENDIX G: 21.5-INCH LCD BRIEF 53

1 Precautions

1.1 Safety Precautions

In order to use this product safely, please take special note of the following precautions.

- Read all product manuals and related documentation before using this product. Use this product correctly and safely. Follow all warnings.
- If operating or extending this product in a manner not described in this manual, please do so at your own risk. Be sure to fully read this manual and other technical information on our website and proceed safely and responsibly.
- Do not install this product in a place with a lot of water, moisture, dust or soot. This could cause product failure, fire, or an electric shock.
- Some parts of this product generate heat and can reach high temperatures. This may cause burns if it is improperly handled. Do not touch the electronic components or surrounding area while powered on or immediately after being turned off.
- Carry out any design and development only after you have thoroughly read and understood this manual and any other related technical materials on the website or in the data sheets. Test your product thoroughly for reliability and safety.
- This product is not intended for applications that require extremely high reliability, safety, functionality and accuracy: including but not limited to medical equipment, traffic control systems, combustion control systems, and safety equipment. This company is not liable for death or injury if used in such systems.
- This product uses semiconductor components designed for generic electronics equipment such as office automation, communications, measurement equipment and machine tools. Foreign noise or a power surge may cause this product to malfunction or fail.
- To ensure there is no risk of bodily harm or property damage, be sure to take all electrical safety precautions such as protection circuits, limit switches, fuse breakers, or redundant systems. Only use the device after sufficient reliability and safety measures are in place.

1.2 Write Prohibited Regions

Data stored by the EEPROM, i.MX6Q/D electrical fuse (e-Fuse) is used by the software contained in this product. Do not write to these regions as this may cause the product stop working correctly. Purposely writing to these regions voids the product warranty.

1.3 Warranty

As described in the Product Warranty Policy provided with this product, the main board is covered by a one year replacement warranty starting from the time of purchase. Please note that the other included goods and software are not covered under this warranty. Some knowledge used by IC-NEXUS is provided by third parties, and IC-NEXUS makes no representation or warranty as to the accuracy of such information.

2 Product Features

2.1 Overview

The SBC21/NSD21/EC21 is a series of Freescale iMX6 ARM Cortex-A9 based embedded computer products with a rich set of features. It is a flexible, high performance and inexpensive computer platform designed for multimedia applications such as digital signage, in-vehicle infotainment, KIOSK or HMI.

Each device can be installed in advance with Windows Embedded Compact 7, Ubuntu 11.10 or Android 4.2 for immediate evaluation.

The Cortex-A9 series of products include the following models:

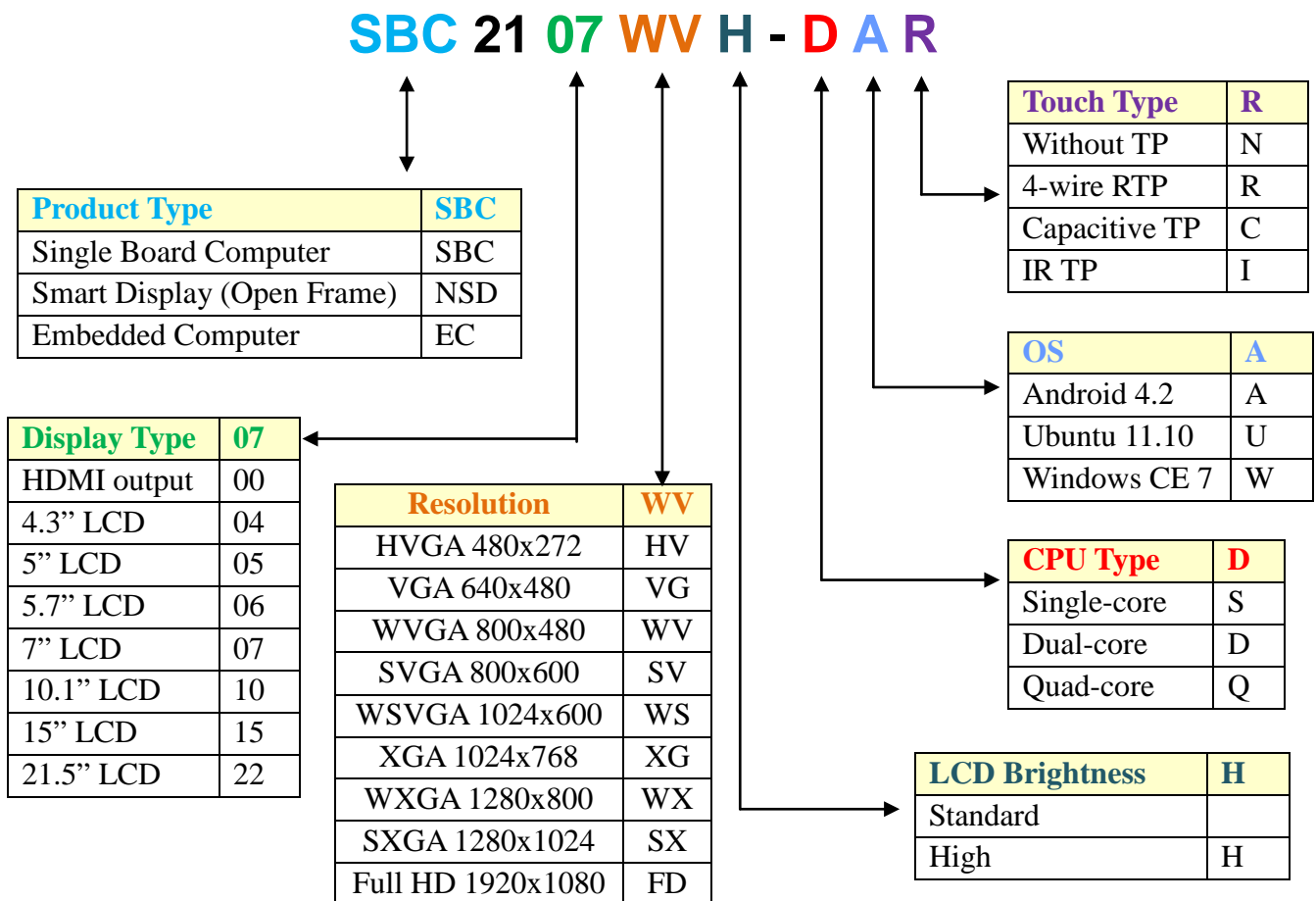

Figure 1: Product Number Naming Conventions

2.2 Features and Specifications

Features

- High performance Cortex A9 processor (quad/dual/single core)
- Dedicated hardware MPEG2/4/H.264 1920x1080 Full HD decoder
- Dedicated hardware H.264 1920x1080 Full HD encoder
- Hardware 2D/3D graphics accelerator
- Preinstalled Windows Embedded Compact 7, Ubuntu 11.10 or Android 4.2 OS
- Rich set of peripherals (LCD, USB, HDMI, ...etc)

SBC/NSD/EC21 Series Specifications

- Freescale iMX6 ARM Cortex™-A9 core @ 1 GHz, 32 KB L1 cache, 512 KB L2 cache
- 1GB DDR3 SDRAM (Single Core with 512MB DDR3 only)
- 4GB eMMC Flash
- Hardware Video Decoder
 - H.264 HP profile (up to 50 Mbps)
 - MPEG 1/2 MP profile (up to 50 Mbps)
 - MPEG 4 SP/ASP profile (up to 40 Mbps)
 - VC1 SP/MP/AP profile (up to 45 Mbps)
- Hardware Video Encoder
 - MPEG 4 Simple profile 720P 30fps (up to 12 Mbps)
 - H.264 BP/CBP profile 1080P 30fps (up to 14 Mbps)
- 10/100/1000 Mbps Gigabit Ethernet interface RJ-45 connector x1
- Single parallel 24-bit display port, up to 225 Mpixels/sec
- LVDS serial ports - Single port up to 165 Mpixels/sec or dual ports up to 85 MP/sec
- 7", or 10.1" LCD panel with touch screen x1
- HDMI 1.4 transmitter connector x1
- +12V DC power input connector x1
- USB 2.0 host connector x2
- USB 2.0 OTG connector x1
- Micro SD card socket x1
- SATA x1
- SGTL5000 Audio Codec , Amplifier circuit
- MIC-in connector x1, Earphone connector x1
- Speaker connector x2 (L/R)
- RS485 connector x1

- RS232 connector x2 (one for debug port)
- GPIO pin header x1 (**8 bits for Standard; 16 bits for Optional**)
- CAN bus phoenix connector x 1 (**Optional**)
- IEEE 802.11 b/g/n Wi-Fi x 1 (**Optional**)
- mini PCI-E for 3G module x 1 (**Optional**)
- MIPI interface x 1 (**Optional**)
- Board Dimension: 101mm x146mm

3 Interface Spec - I (EC21/NSD21/SBC21)

The following photos and diagrams show connector positions on the SBC21 and EC21 series of products respectively. The functional details of the connectors are described in subsequent sections.

Major connectors of SBC2100 PCB:

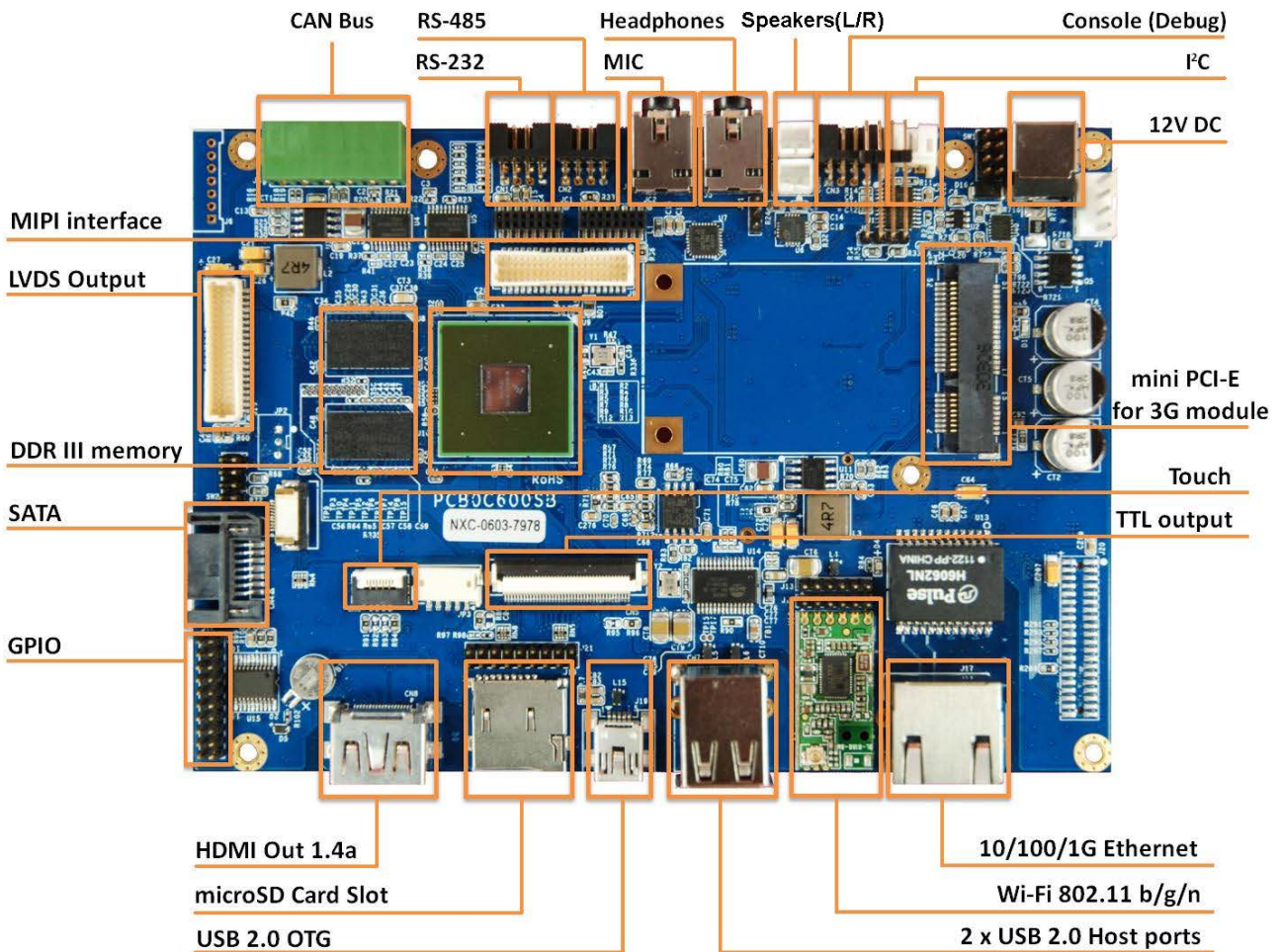

SBC2100 PCB Top View

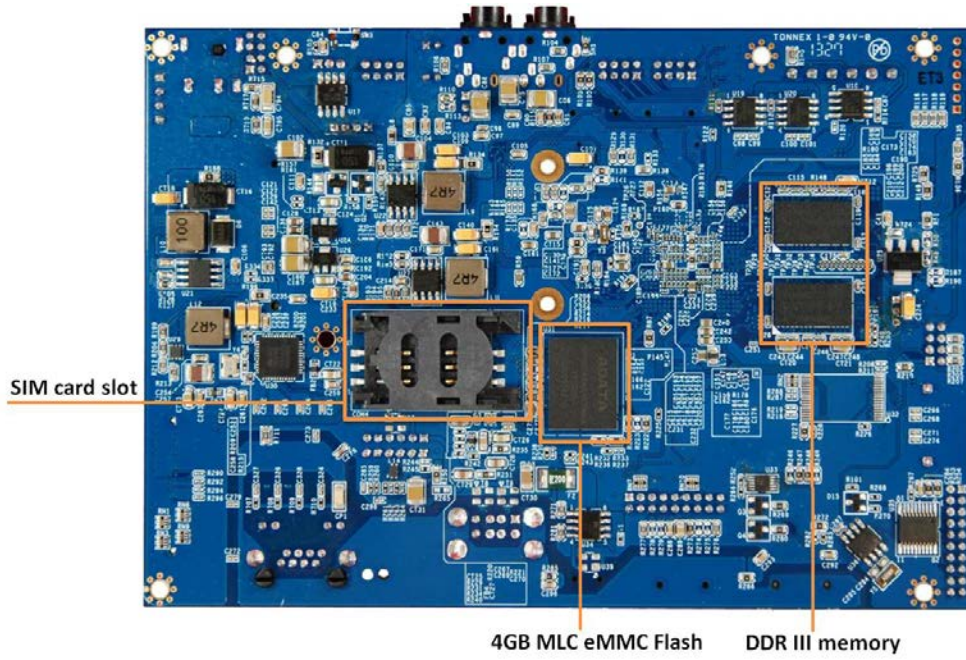

SBC2100 PCB Bottom View

Connector positions of EC21 series:

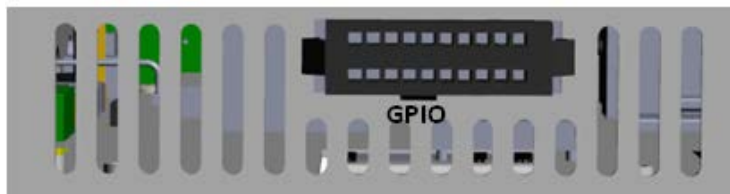
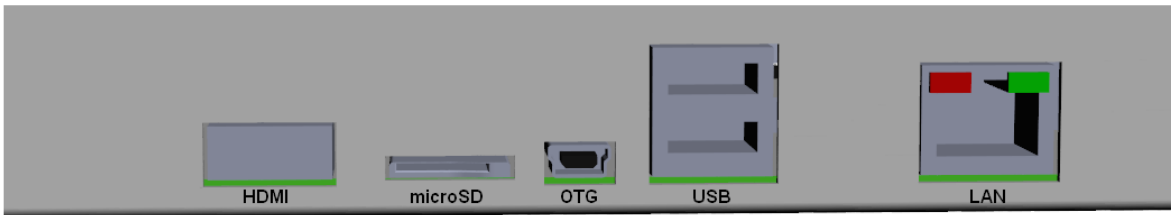
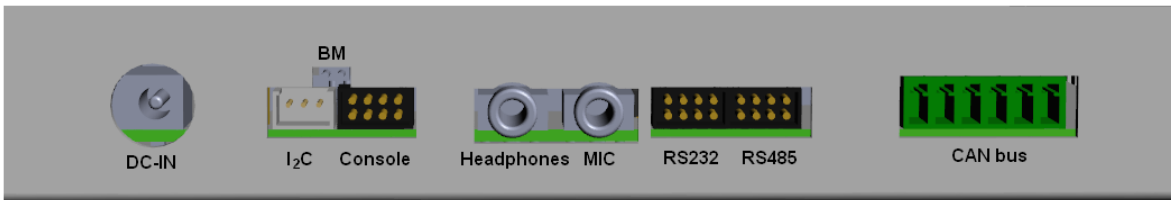

3.1 HDMI Connector

The HDMI receptacle connector supports a standard HDMI interface. Its features include:

- HDMI 1.4a, HDCP 1.4, DVI 1.0 compliant
- Hot plug/unplug detection and link status monitor supported
- Video resolutions supported:
 - Up to 1080p@120Hz HDTV display
 - QXGA graphics display
 - HDMI 1.4a 4K x 2K video formats
 - HDMI 1.4a 3D video modes with up to 340MHz TMDS clock
- Supported color formats:
 - 24/30/36/48-bit RGB 4:4:4
 - 24/30/36/48-bit YCbCr 4:4:4
 - 16/20/24-bit YCbCr 4:2:2
- All audio formats as specified by the HDMI Specification Version 1.4a are supported
- HDMI pin out

Pin	Signal	Pin	Signal
1	TMDS Data2+	11	TMDS Clock Shield
2	TMDS Data2 Shield	12	TMDS Clock-
3	TMDS Data2-	13	CEC
4	TMDS Data1+	14	NC
5	TMDS Data1 Shield	15	SCL
6	TMDS Data1-	16	SDA
7	TMDS Data0+	17	Ground
8	TMDS Data0 Shield	18	+5V
9	TMDS Data0-	19	Hot plug detect
10	TMDS Clock+		

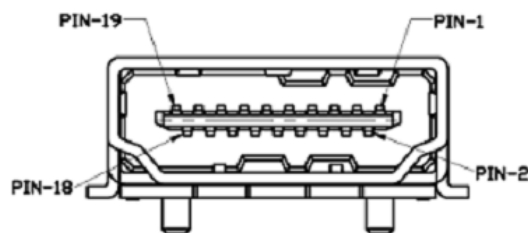

3.2 MicroSD Connector

The microSD host connector has the following specification:

- SD Host Controller Standard Specification version 3.0
- MMC System Specification version 4.2/4.3/4.4
- SD Memory Card Specification version 3.0 and supports the Extended Capacity SD Memory Card
- SDIO Card Specification version 3.0

microSD Connector Pin-out

Pin	Signal	Pin	Signal
1	Data 2	6	GND
2	Data 3	7	Data 0
3	CMD	8	Data 1
4	VDD	9	CD
5	CLK		

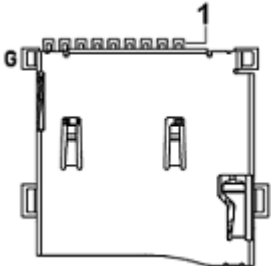

The diagram shows a top-down view of the microSD connector. It features a 9-pin header. Pin 1 is labeled '1' and is connected to 'Data 2'. Pin 2 is labeled '2' and is connected to 'Data 3'. Pin 3 is labeled '3' and is connected to 'CMD'. Pin 4 is labeled '4' and is connected to 'VDD'. Pin 5 is labeled '5' and is connected to 'CLK'. Pin 6 is labeled '6' and is connected to 'GND'. Pin 7 is labeled '7' and is connected to 'Data 0'. Pin 8 is labeled '8' and is connected to 'Data 1'. Pin 9 is labeled '9' and is connected to 'CD'. The diagram also shows the physical layout of the pins and the connector housing.

3.3 UART Connectors & Debug Port

There are 3 UART ports on this device. The connector type and functions are described in the table below:

UART Number	Connector Type	Available Signals	Notes
UART1	2x4 box header	RS232 signal level (TX, RX, RTS, CTS)	Console/Debug port
UART2	2x4 box header	RS232 signal level (TX, RX, RTS, CTS)	RS232 port
UART3	2x4 box header	RS485 signal level (485+, 485-)	RS485 port Note: RS485 port works only in HALF Duplex mode

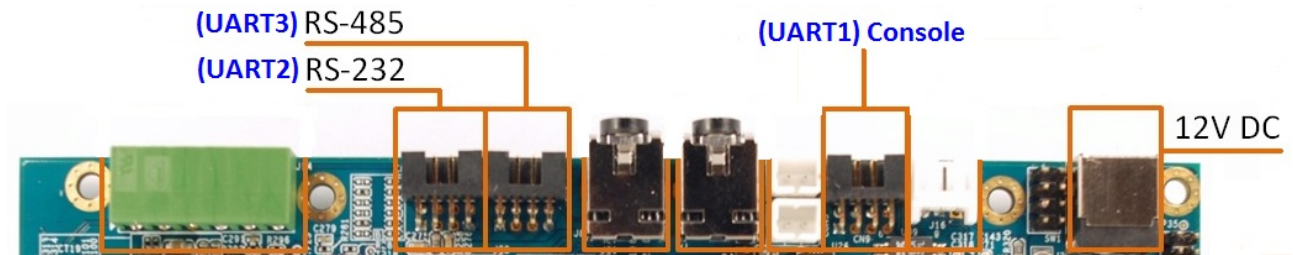

One 2x4 box header to DB9 cable is included. See [Appendix A](#) for the detailed info on the cable pin assignment.

2x4 Box Header:		DB9 Pin	2x4 header	RS232	RS485
		1	--	---	---
		2	4	RxD	485+
		3	6	TxD	485-
		4	1	---	---
		5	5	GND	GND
		6	7	---	---
		7	8	RTS	---
		8	2	CTS	---
		9	--	---	---

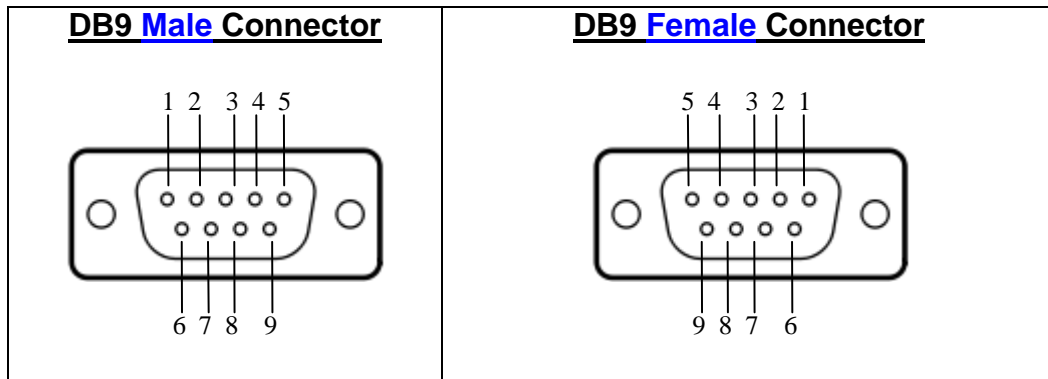

UART1 Connection Diagram:

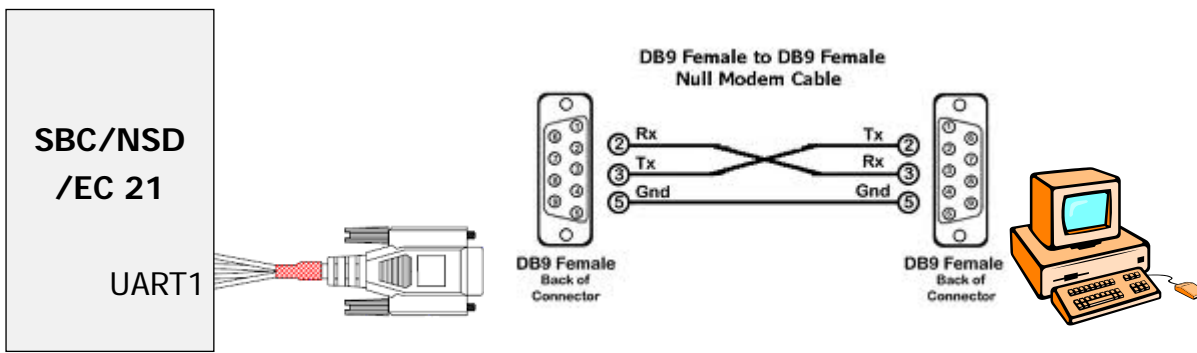

UART1 is dedicated as the debug port. UART1 default settings are **Baud Rate 115200, 8 data bits, no parity, 1 stop bit and no flow control.**

A DB9 **null modem cable** (or adapter) is required when you want to connect UART1 to a PC with terminal emulation software such as TeraTerm.

UART1 Box Header (CN3 on PCB) Pin Assignment:



UART2 Connection Diagram:

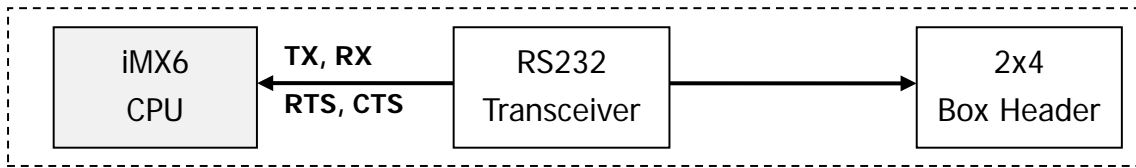

UART2 (with TX, RX, RTS, CTS signals) works as a regular RS232 port.

UART2 Box Header (CN2 on PCB) Pin Assignment:

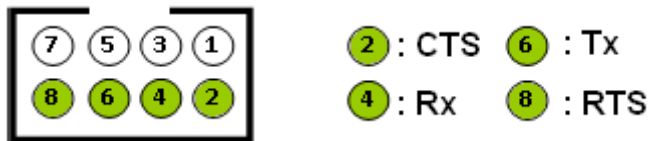

UART3 Connection Diagram:

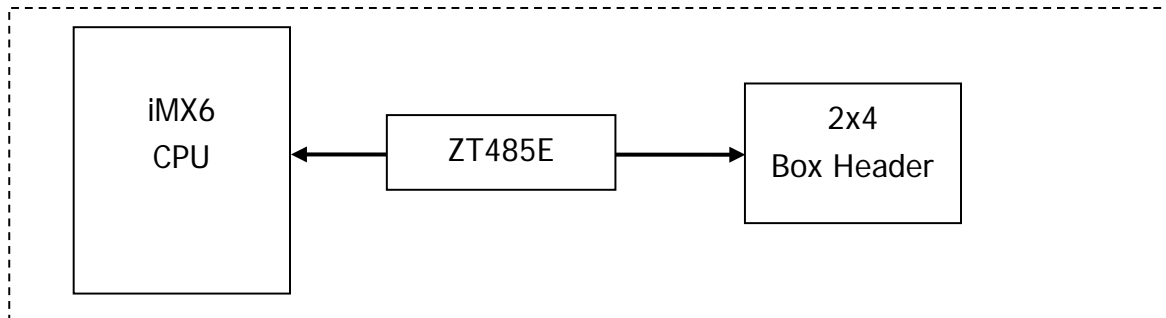

ZT485E: RS485 transceiver. RS485 works in half duplex mode.

UART3 Box Header (CN1 on PCB) Pin Assignment:

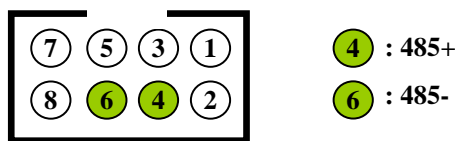

3.4 USB Connectors

The USB interfaces on SBC/NSD/EC21 include a USB 2.0 OTG port and two USB2.0 host ports. Speed of up to 480 Mbps supported.

The USB 2.0 host interface is connected to a hub controller to extend host ports. Two of the USB2.0 hub ports are available for users. The other two USB ports are reserved for 802.11b/g/n WiFi module and 3G (WCDMA) module.

USB Port:

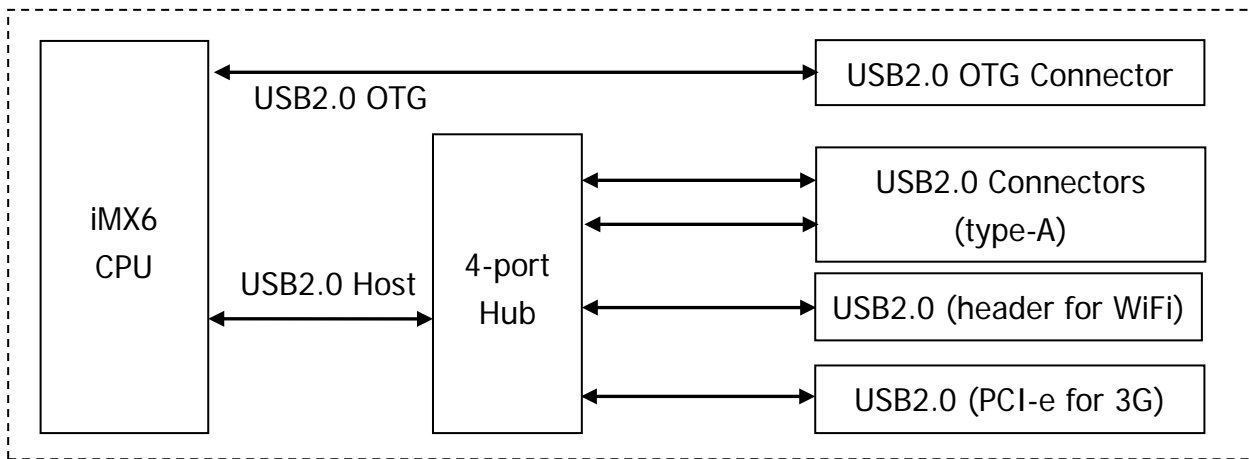

NOTE: The USB 2.0 OTG can be used in host mode or device mode. If you would like to use it in host mode, a separate OTG-to-host cable is required.

The USB 2.0 host connector is a regular USB type A connector that can be connected to +5V USB storage device. This port is mainly used to connect to USB flash drive.

Pin	Signal	Pin	Signal
1	5V	1	5V
2	Data -	2	Data -
3	Data +	3	Data +
4	GND	4	ID
		5	GND

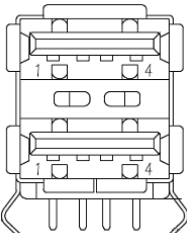
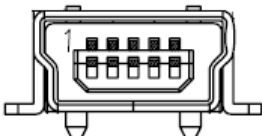
USB port 2 is connected to J13 pin header and to PCI-e connector for 3G module.

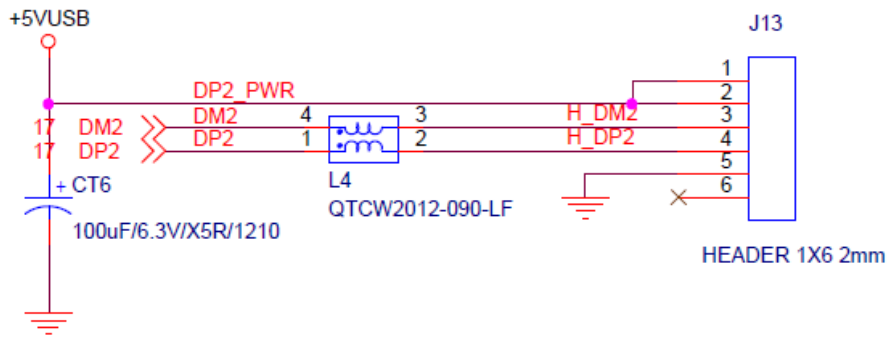

USB port 3 is connected to J14 pin header for 802.11b/g/n module.

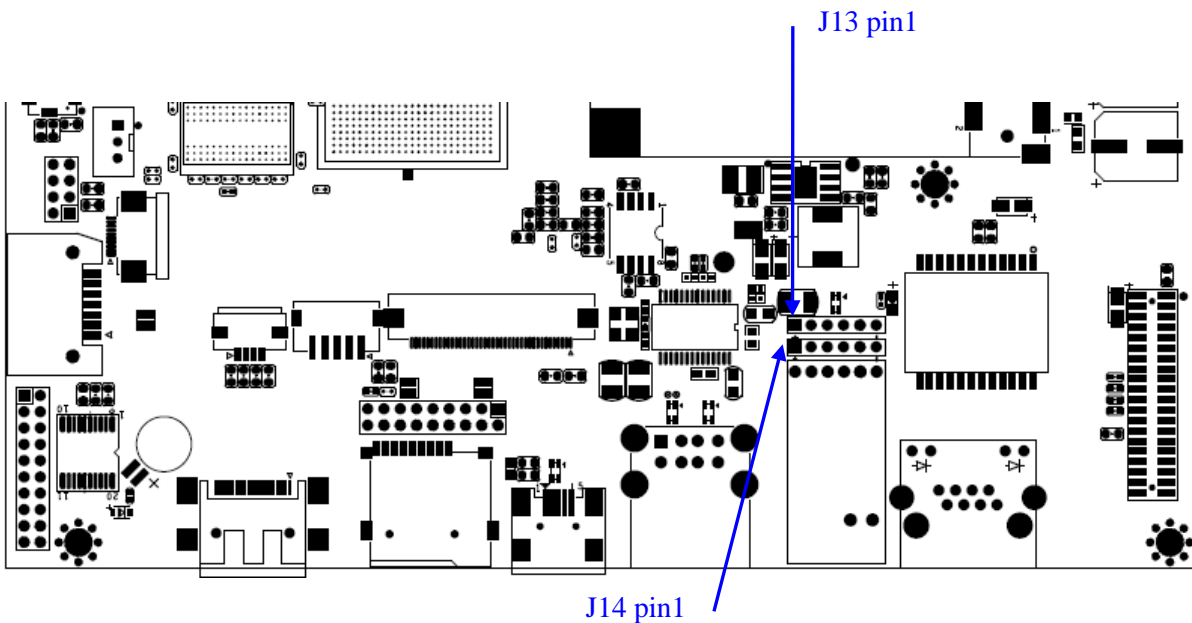
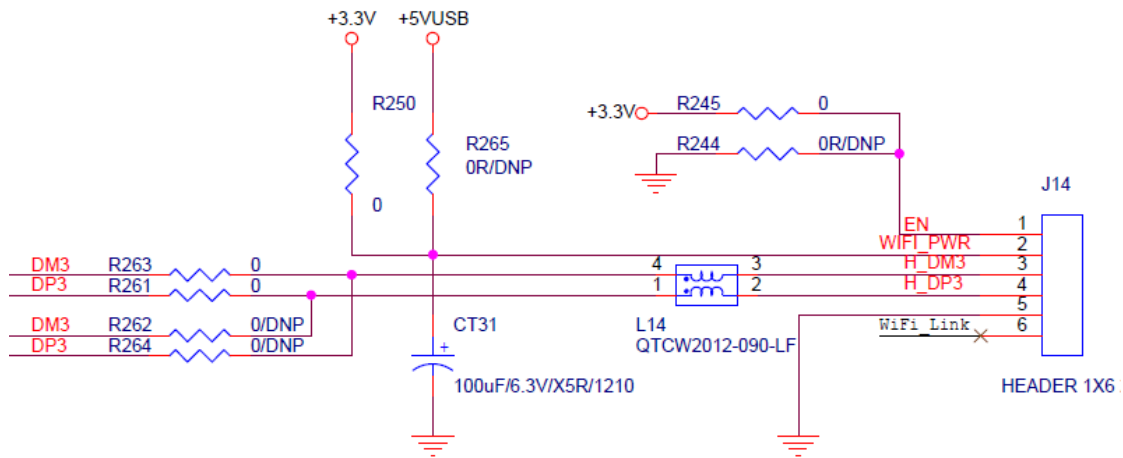

3.5 Audio Interface

The audio interface is implemented by a SGTL5000 audio codec. The data and control interface between CPU and SGTL5000 is I²S.

The available audio connectors are MIC-in, Headphone-out, speaker Left and speaker Right. The Line-in interface is connected to pin header JP1.

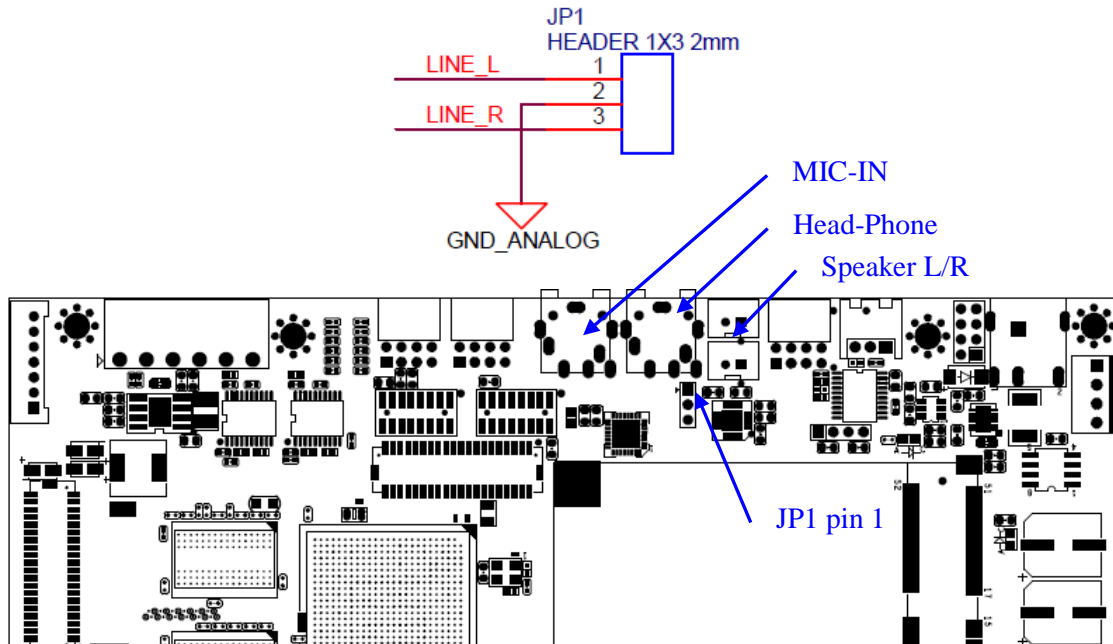

Audio Interfaces:

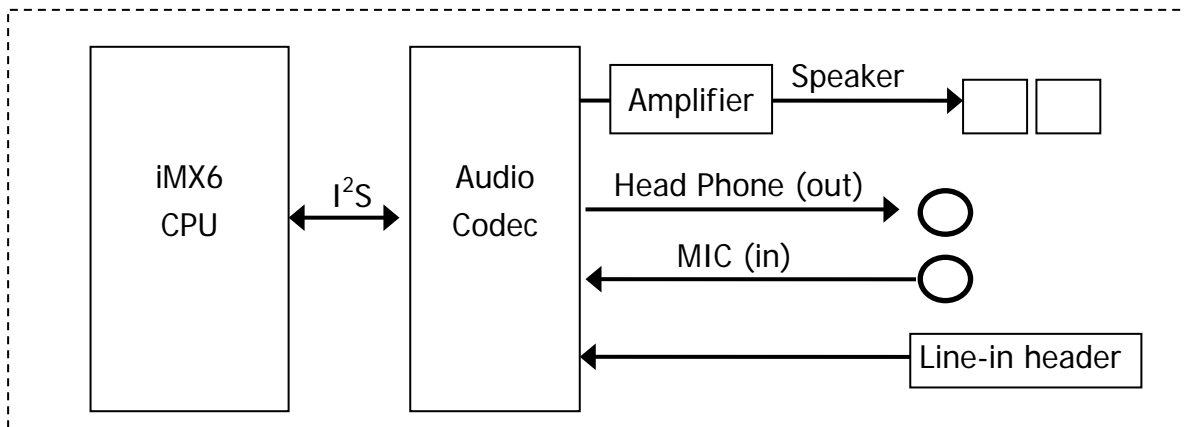

3.6 Ethernet Interface

The 10/100/1000 Mbps Gigabit Ethernet interface is available with a standard RJ-45 connector.

Ethernet:

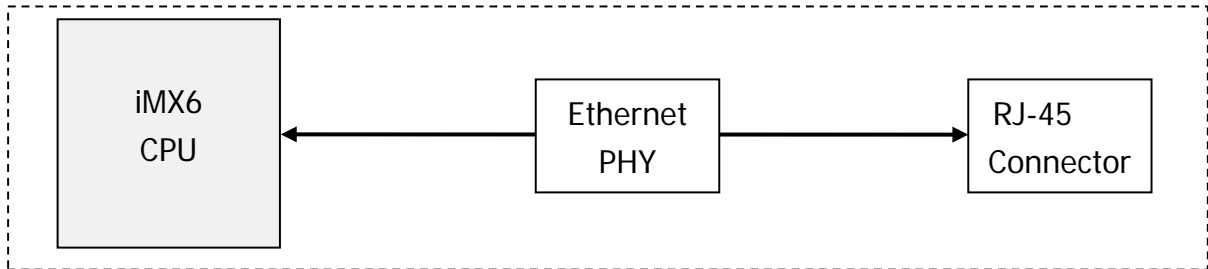

3.7 Power Supply (DC-IN connector)

The standard DC power adapter included with SBC/NSD/EC21 is +12V at 1.5A or higher. Power input should be applied to the DC-IN connector.

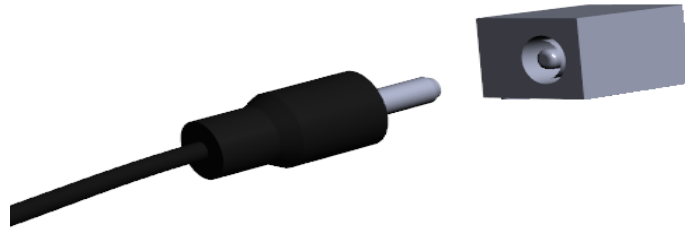

3.8 GPIO Pin Header

The GPIO pin header provides user to connect up to 16 GPIO devices (+3.3V signal level).

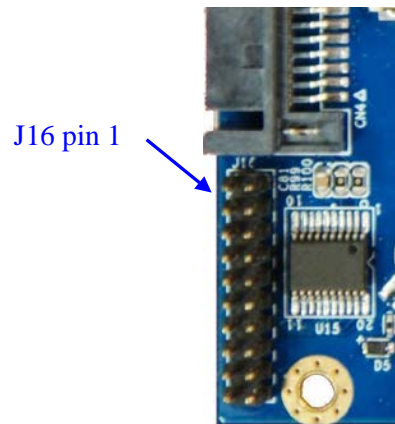
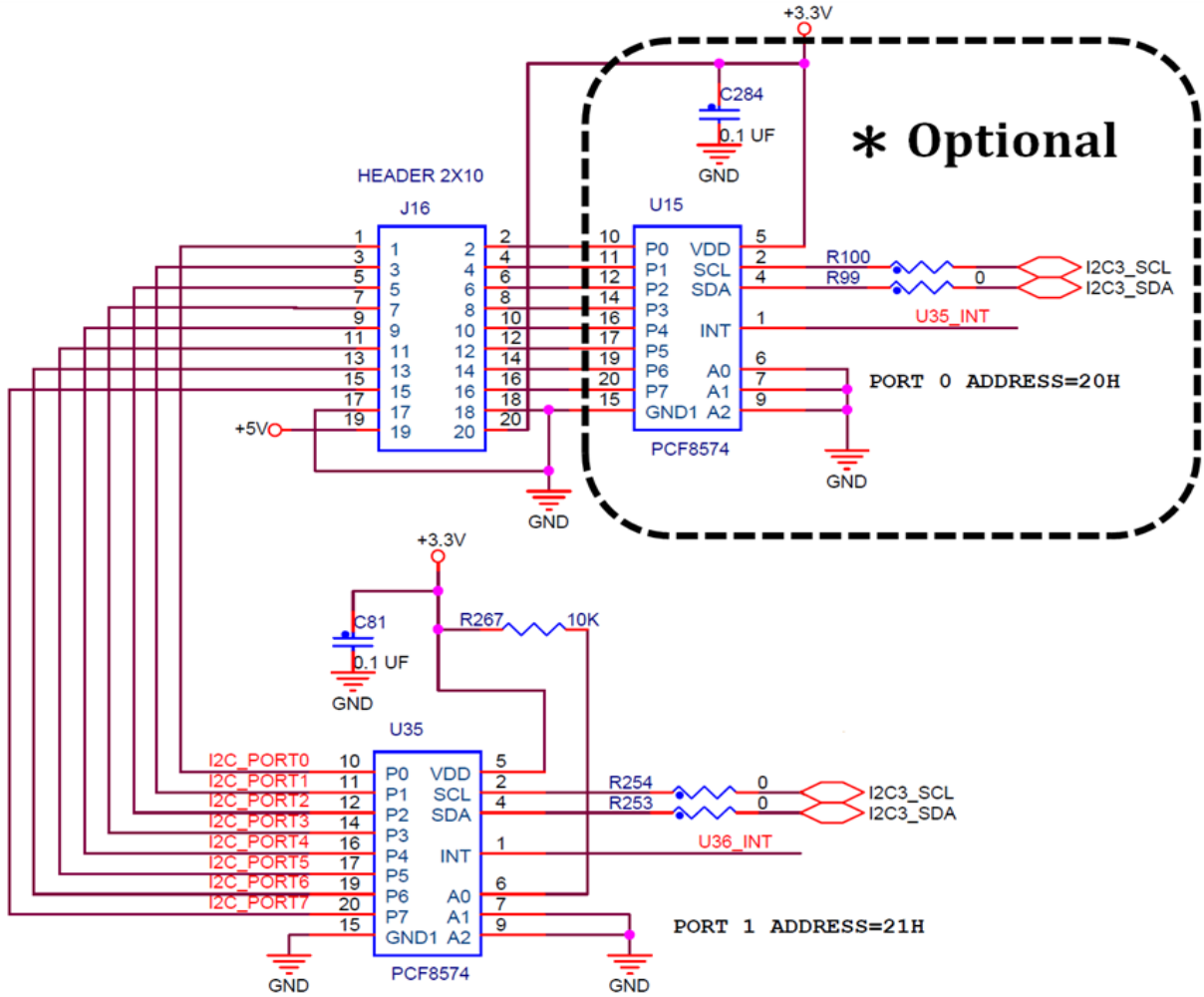

SBC2100 GPIO Connector:

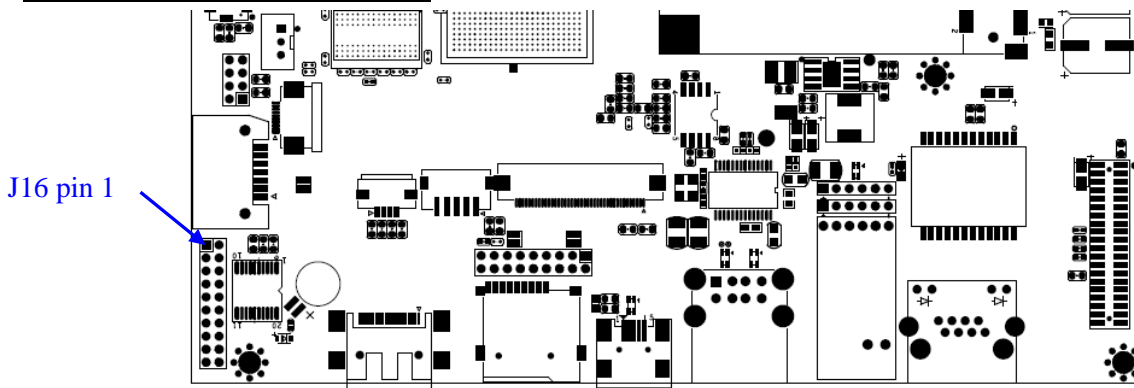

EC21xx GPIO Connector:

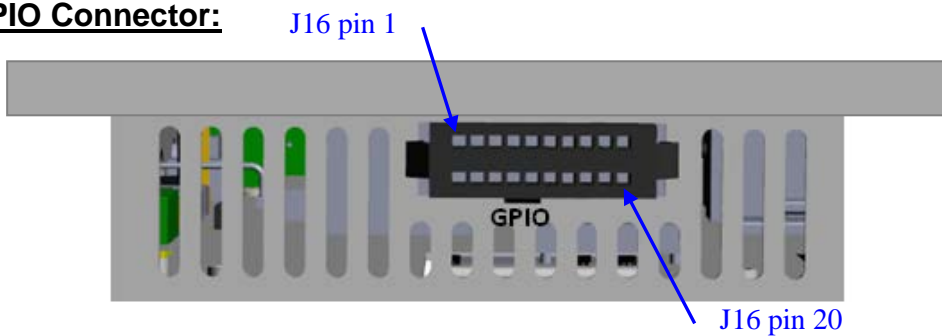

GPIO pin assignment:

J16 pin #	1	3	5	7	9	11	13	15	17	19
Port-pin	1-P0	1-P1	1-P2	1-P3	1-P4	1-P5	1-P6	1-P7	GND	5V
GPIO #	232	233	234	235	236	237	238	239	---	---
J16 pin #	2	4	6	8	10	12	14	16	18	20
Port-pin	0-P0	0-P1	0-P2	0-P3	0-P4	0-P5	0-P6	0-P7	GND	3.3V
GPIO #	224	225	226	227	228	229	230	231	---	---

※Note: 8-bit GPIO (1-P0 to 1-P7) is available on board. 0-P0 to 0-P7 GPIO is optional.

For more information about programming GPIO, please refer to a separate document: "Application Note GPIO".

3.9 I²C Interface

The I²C works as a master port by default: **The master port is pulled high to +3.3V with 2 resistors internally.** The slave devices have to be connected directly without additional power supply on I²C bus.

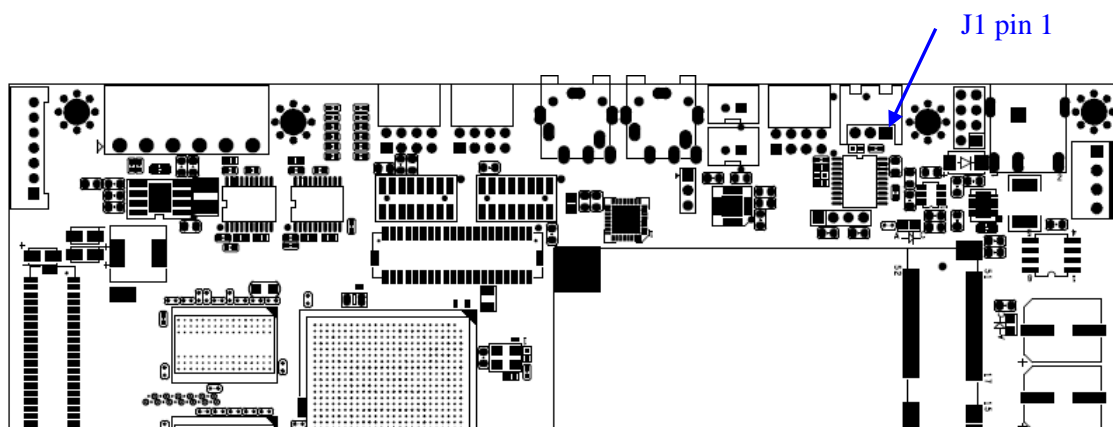
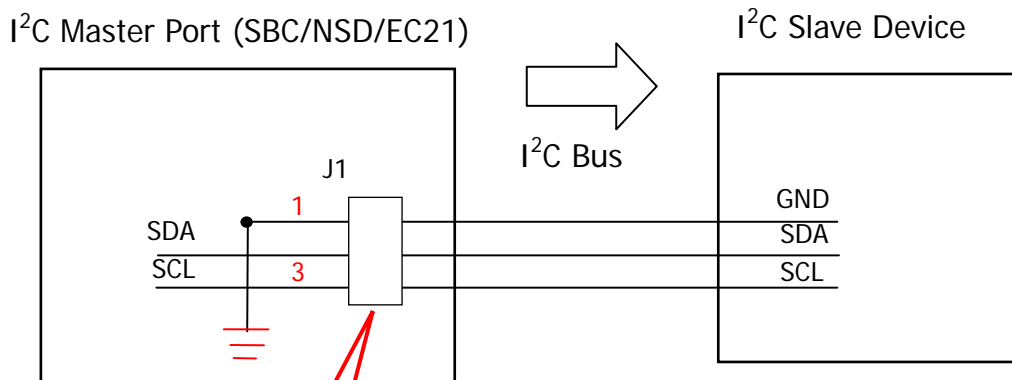

3.10 CAN Bus Interface

The Flexible Controller Area Network (FLEXCAN) module is a communication controller implementing the CAN protocol according to the CAN 2.0B protocol specification

- Version 2.0 B
 - Standard data and remote frames
 - Extended data and remote frames
 - Zero to eight bytes data length
 - Programmable bit rate up to 1 Mb/sec
 - Content-related addressing
- Flexible mailboxes of eight bytes data length
- Listen only mode capability

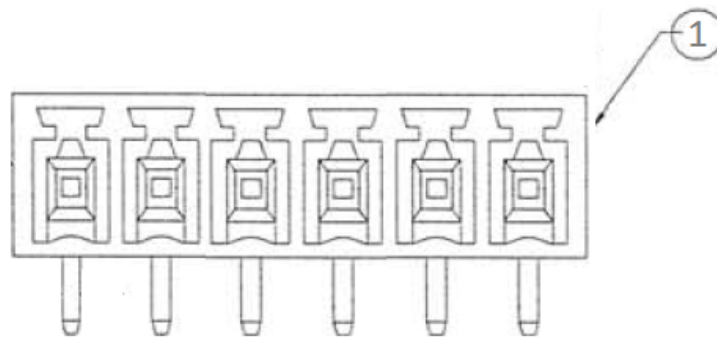

CAN Connector out line

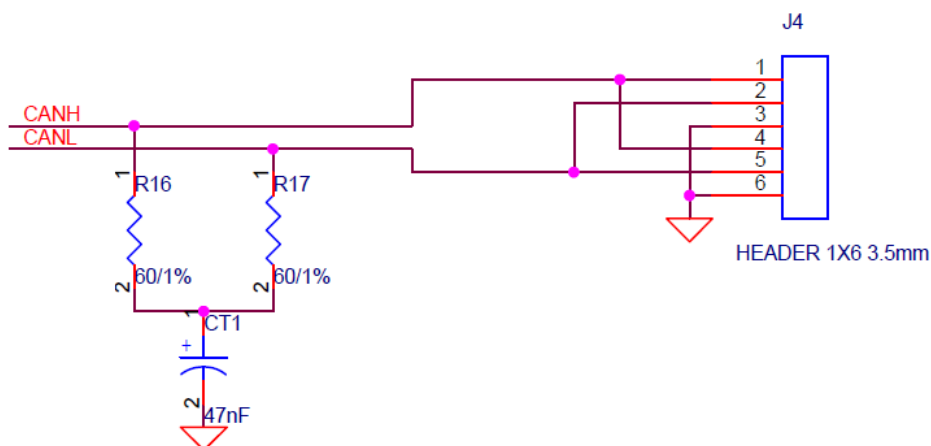

CAN bus schematic

3.11 BM Connector

The J8 connector is used to select the mode of EC21/SBC21/NSD21. For more information on how to burn firmware image, please refer to “Firmware Image Download” application note.



Firmware Download:

Pin 1, 2 open

Pin 3, 4 short



Normal Operation:

Pin 1, 2 short

Pin 3, 4 short

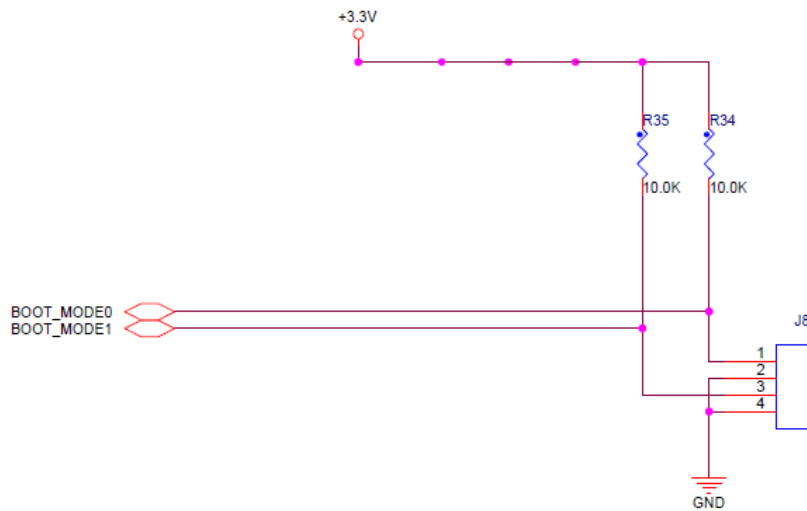

4 Interface Spec - II (NSD21/SBC21 Only)

The interfaces in this chapter are specifically for the SBC21 and NSD21 products.

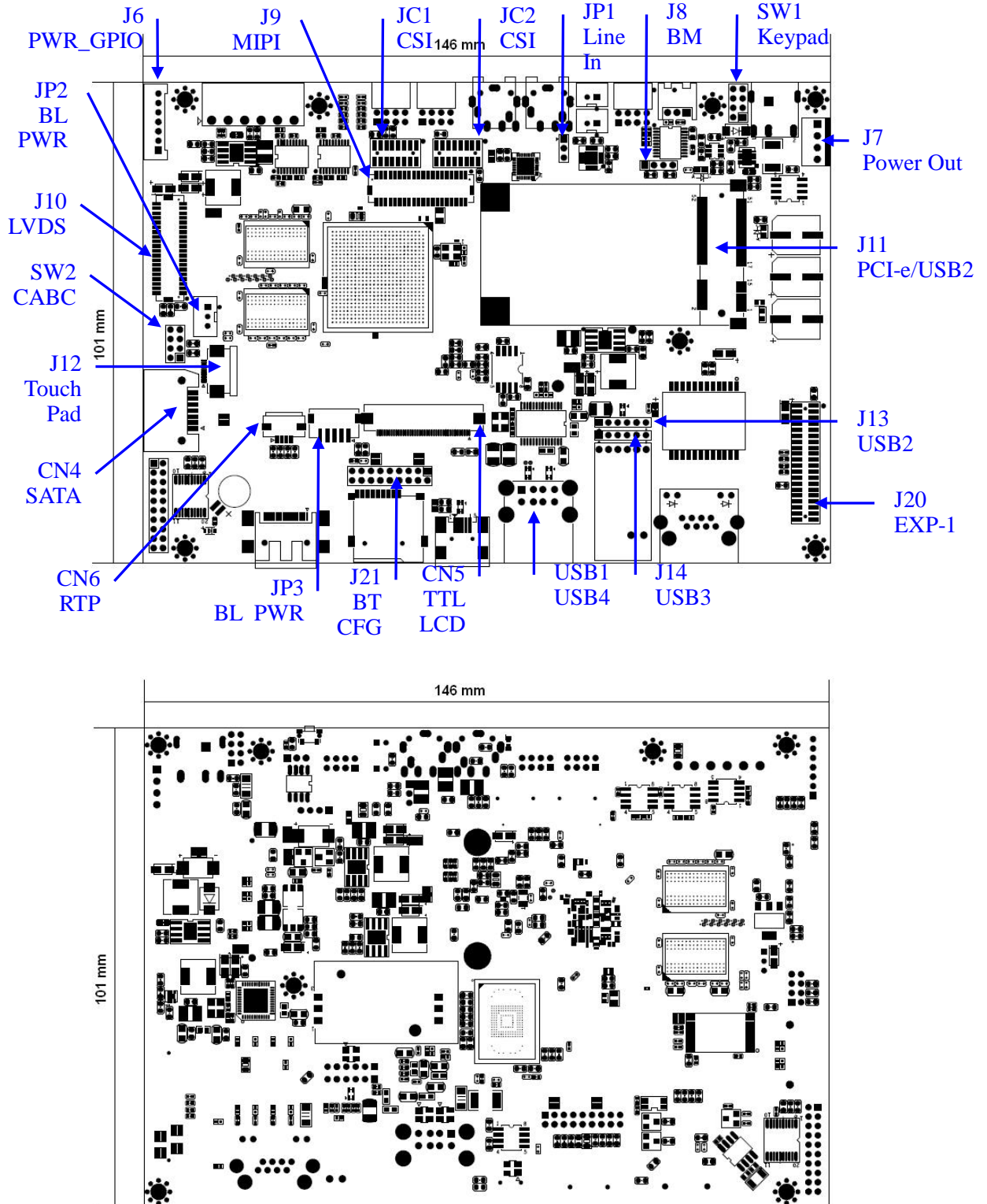

Connector Number	Part Description	Notes
CN5	40pin FPC for parallel display interface	Parallel display interfaces
JP3	TTL LCD backlight power	
J10	LVDS display (dual LVDS channel)	LVDS display interfaces
JP2	LVDS LCD backlight power	
SW2	Reserved for CABC backlight	
CN6	4-wire resistive touch screen interface	Touch screen interfaces
J12	Capacitive touch screen interface	
J7	Power Output	Power output
JC1, JC2	Camera Sensor Interface (CSI)	
J9	MIPI CSI/DSI interface	
J20	EXP-1 (expansion connector)	Expansion connector
SW1	Keypad	
J11	PCI-e form factor with USB2	
J13 / J14	USB2 / USB3 pin headers	Refer to Chapter 3 for USB.
CN4	SATA Interface	
JP1	Audio Line-in pin header	Refer to Chapter 3 for Audio
J8	BM (Mode Selection: burn firmware or normal operation)	Refer to Chapter 3 for BM
J21	BT CFG (reserved)	
J6	Power & GPIO (reserved)	

4.1 Parallel Display Interface

The parallel display interface (CN5) is designed to use with a 7" 800x480 TFT LCD. Other size and resolution of LCDs can also be used with this interface with proper signal connection.

The JP3 backlight connector is reserved for the need to supply a backlight or LCD reset signal to LCD. The schematic of CN5 and JP3 are in below diagram.

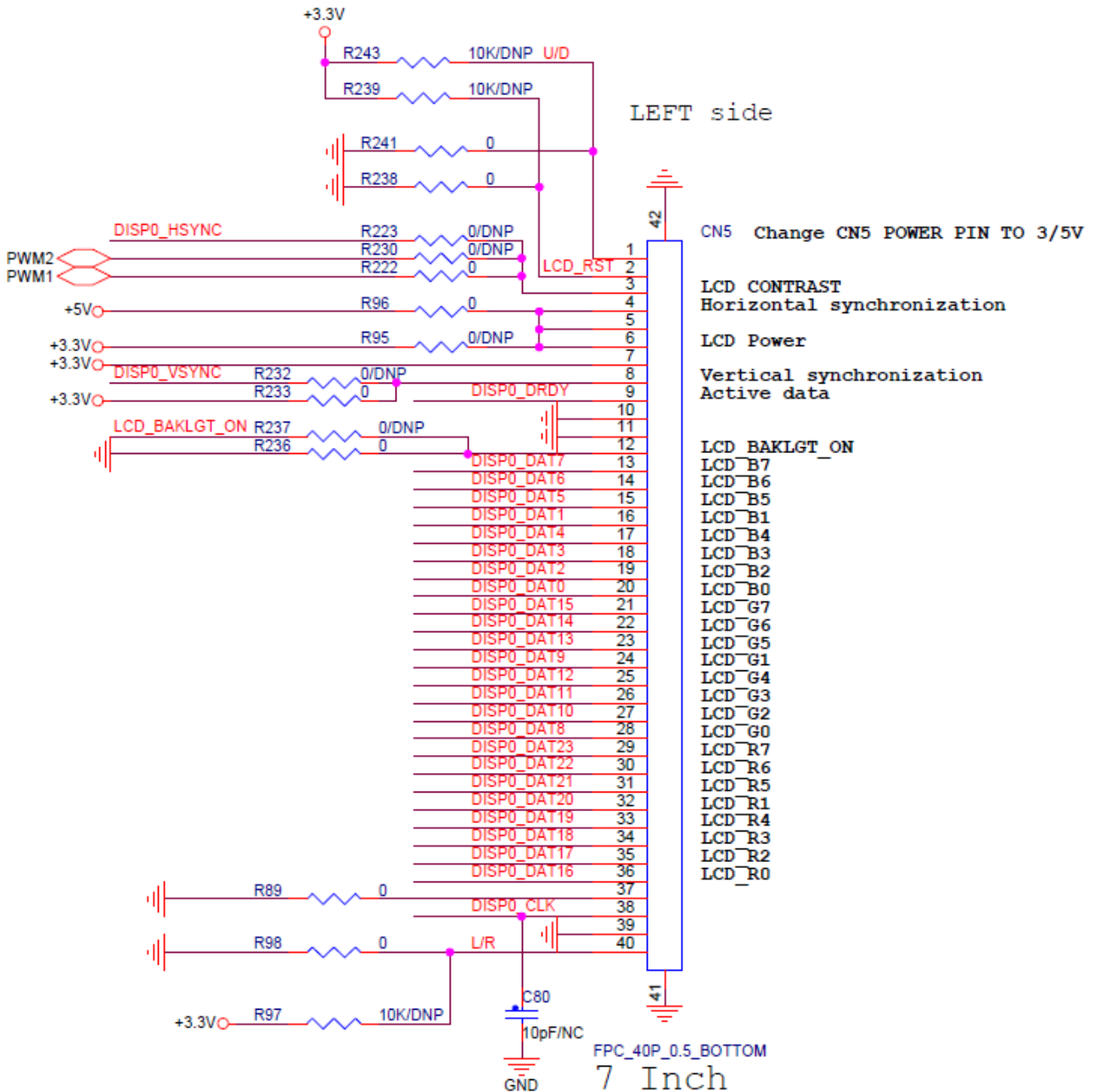

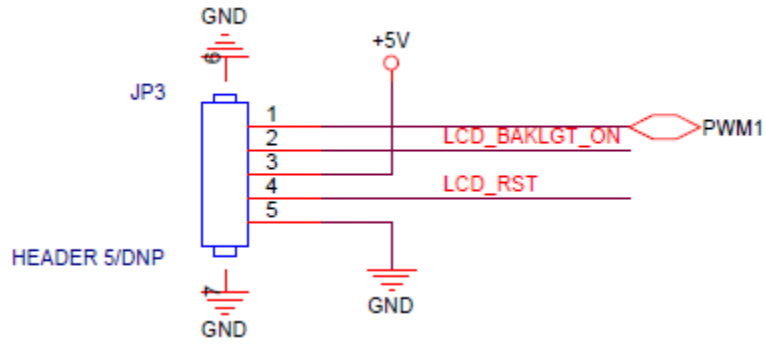

Most of the interface pins are connected directly to iMX6 processor pins. For the electrical DC/AC parameters of the pins, please refer to Freescale iMX6 processor data sheet.

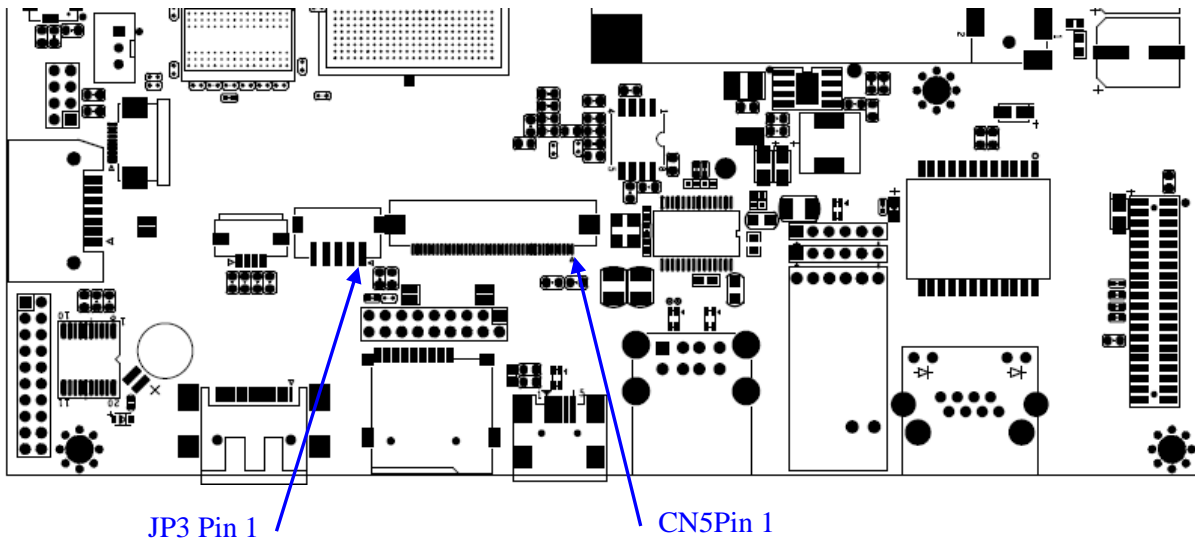

4.2 LVDS Display Interface

There are 2 LVDS channels output on J10 connector. These outputs are used to communicate RGB data and controls to external LCD displays.

The LVDS channels may be used as follows:

- Single channel output
- Two channels outputs for two displays
- Split channel output to a single display

The JP2 pin header is to select a +5V or +12V backlight power to LCD display module.

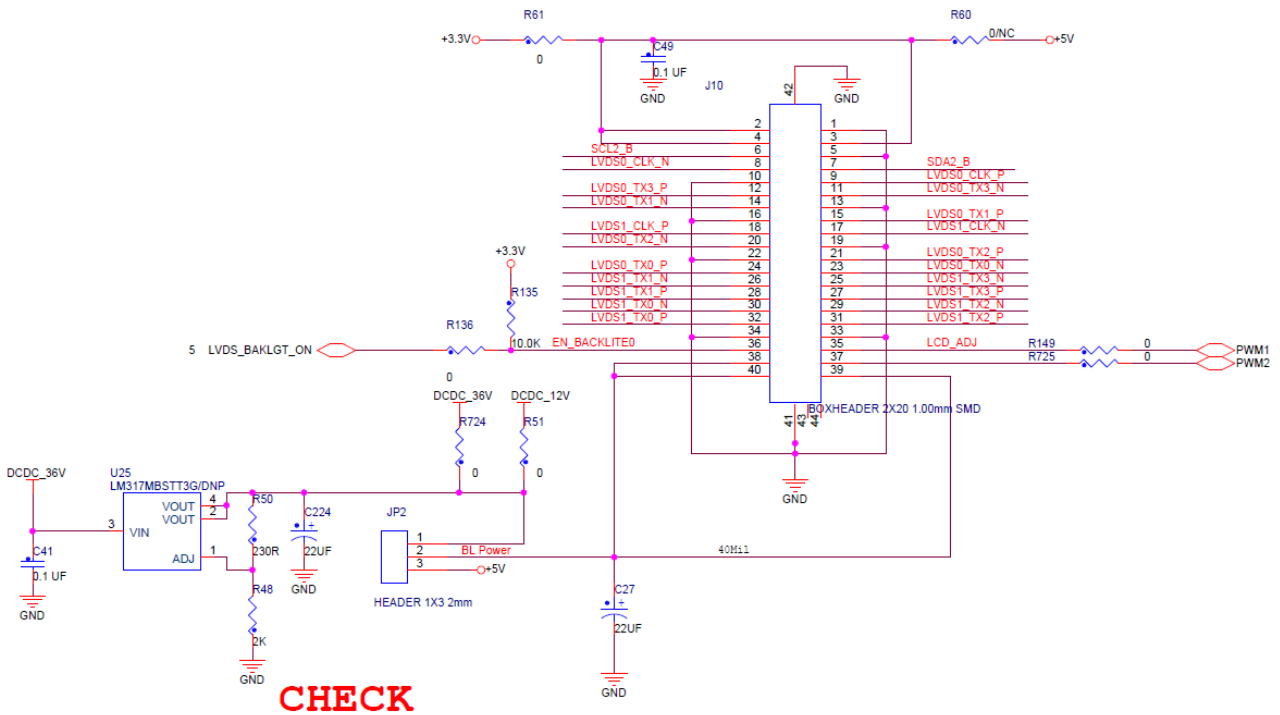

IF INPUT POWER=24V, REMOVE R724 & ADD U25,R50,R48
 IF INPUT POWER=12V, ADD R724 & REMOVE U25,R50,R48

SW2 is reserved for CABC backlight control.

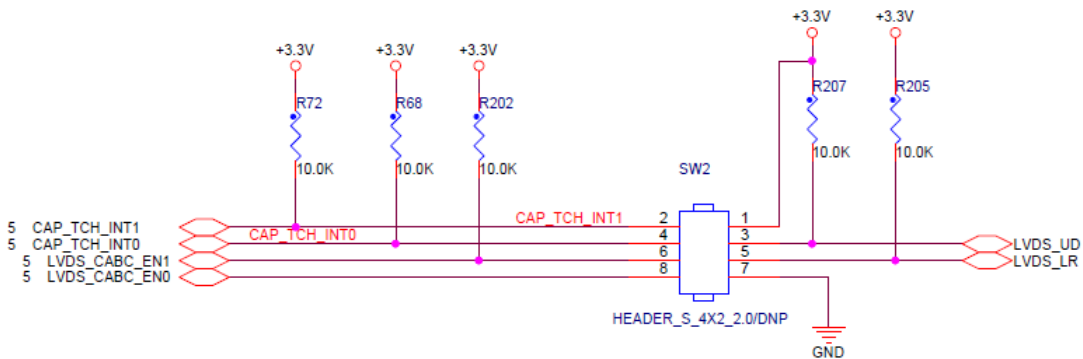

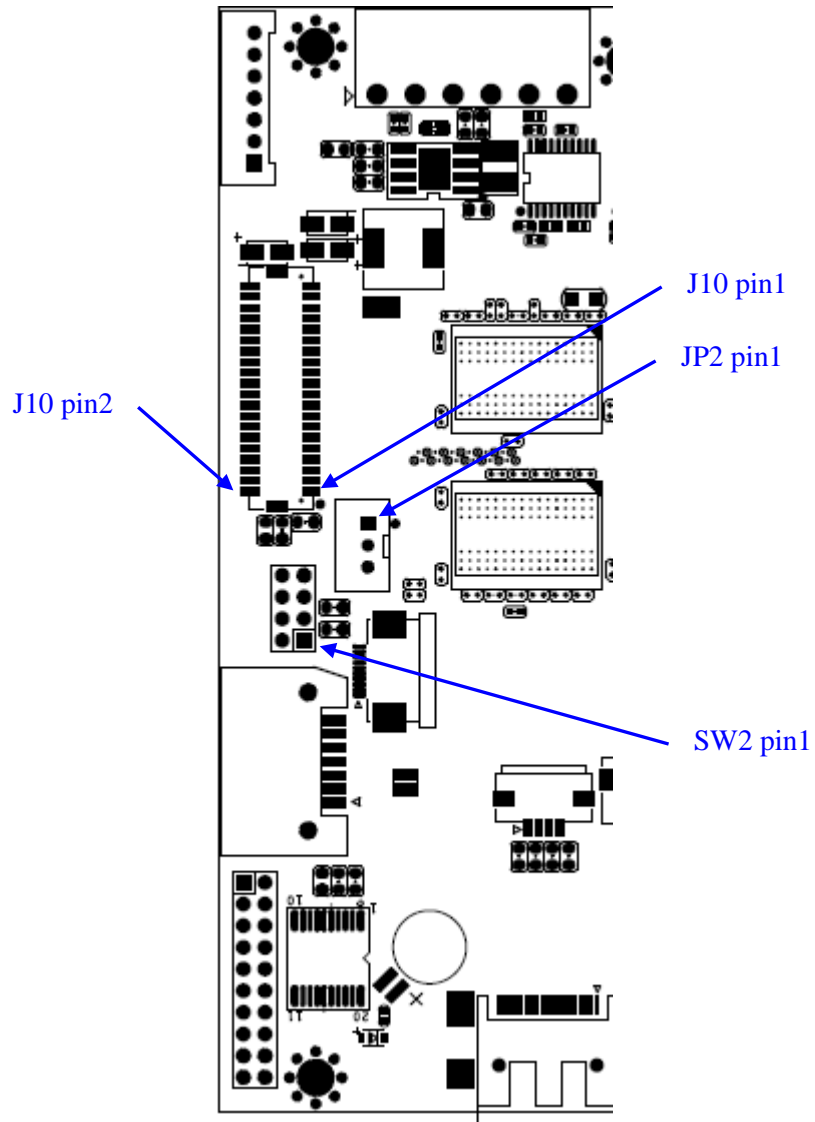

4.3 Touch Screen Interface

CN6 is for connecting to a 4-wire resistive touch screen. The pin assignment can be configured by mounting different resistors as in below schematic.

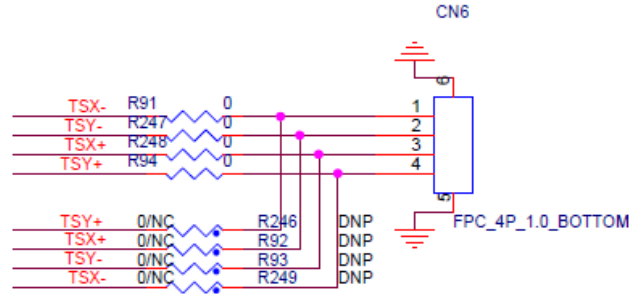

J12 can be used for capacitive touch screen or touch pad interface. In addition to +5V and +3.3V power pins, two GPIO for interrupt, reset and one I2C master port for data are on the connector.

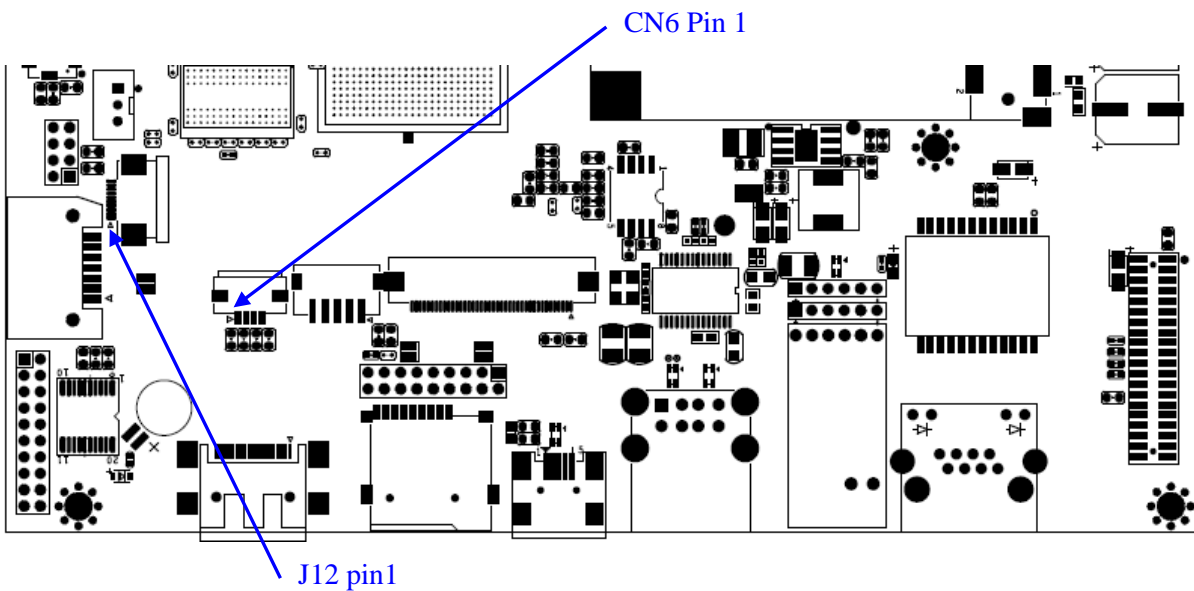
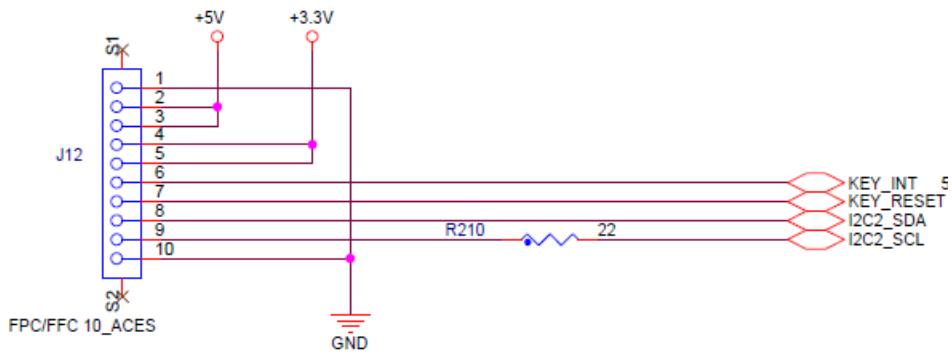

4.4 Power Output Connector

The J7 connector provides +3.3V, +5V, +12V power supply to external devices.

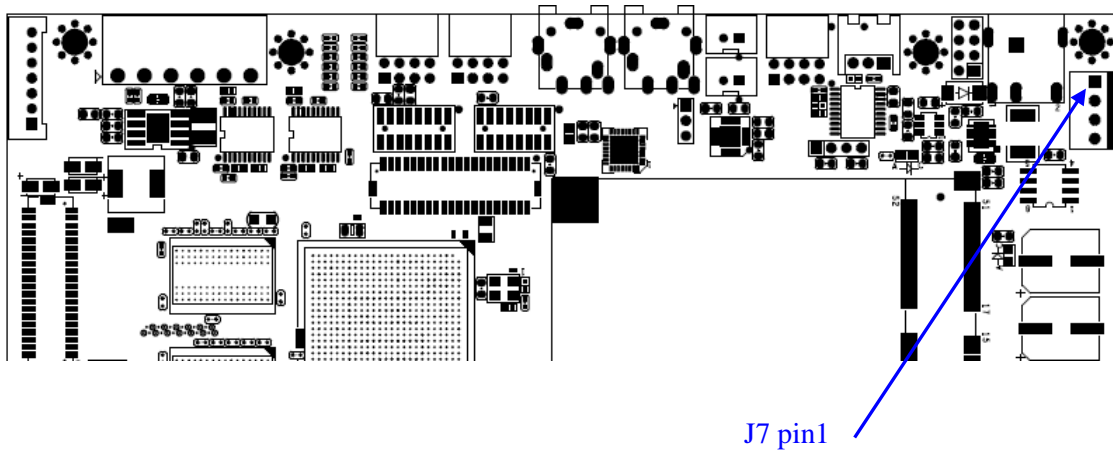
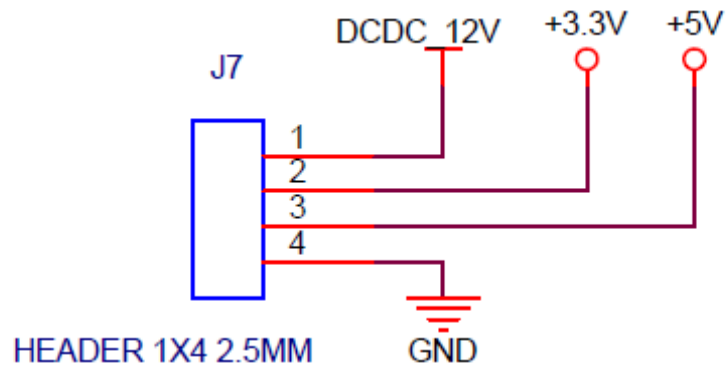

4.5 Camera Sensor Interface

JC1 and JC2 connectors are for parallel camera port. The schematic is as below:

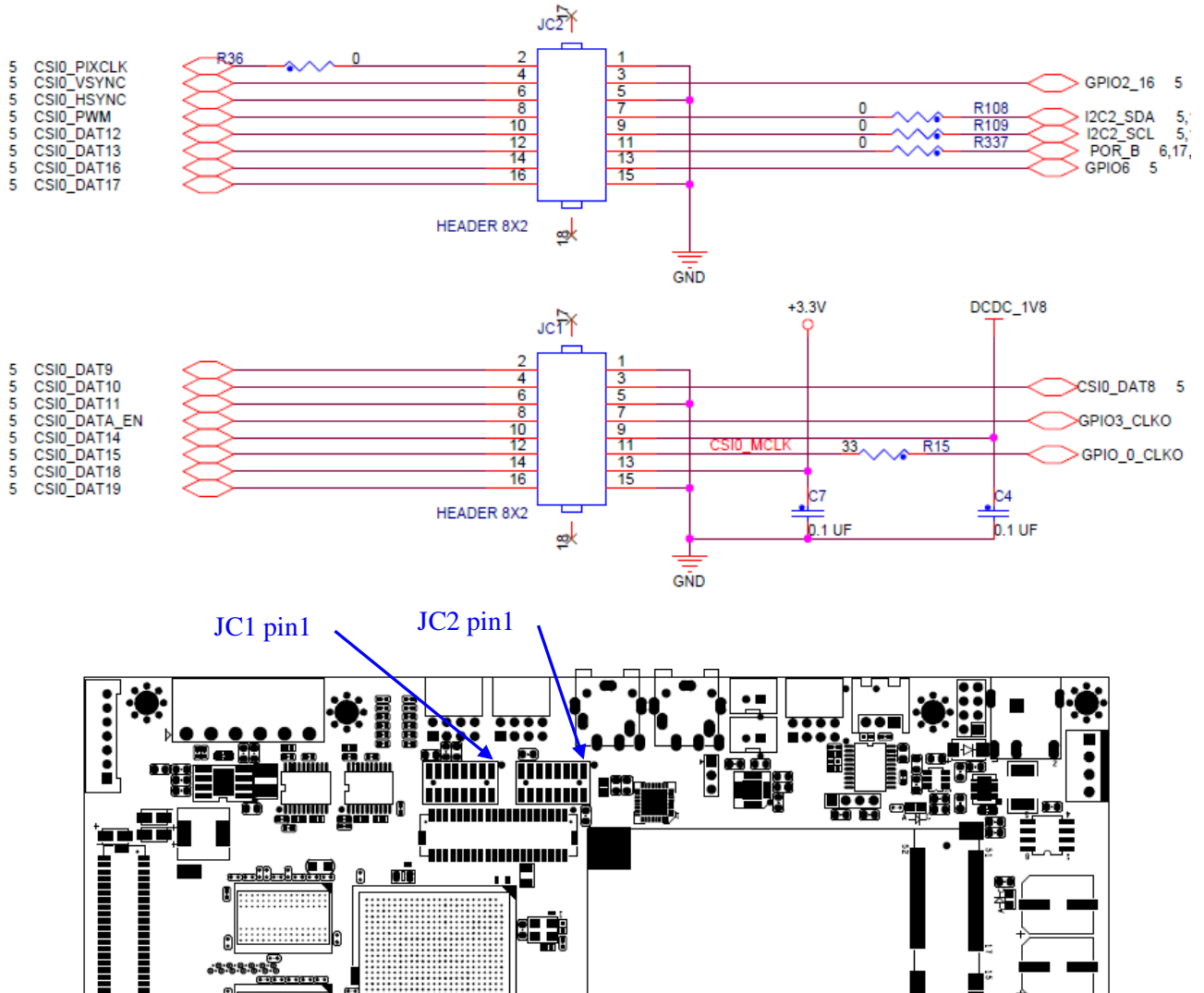

4.6 MIPI Interface

There are 2x MIPI interfaces (DSI and CSI-2) in a single high density connector (J9):

- MIPI/DSI: two lanes at 1 Gbps pixel rate.
- MIPI/CSI-2 serial camera port: supporting up to 1000 Mbps/lane in 1/2/3-lane mode and up to 800 Mbps/lane in 4-lane mode. The CSI-2 Receiver core can manage one clock lane and up to four data lanes.

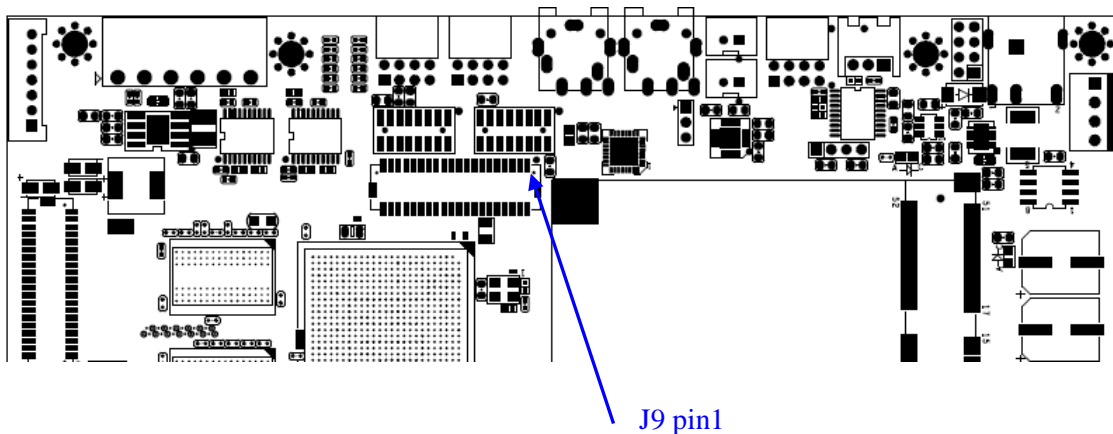
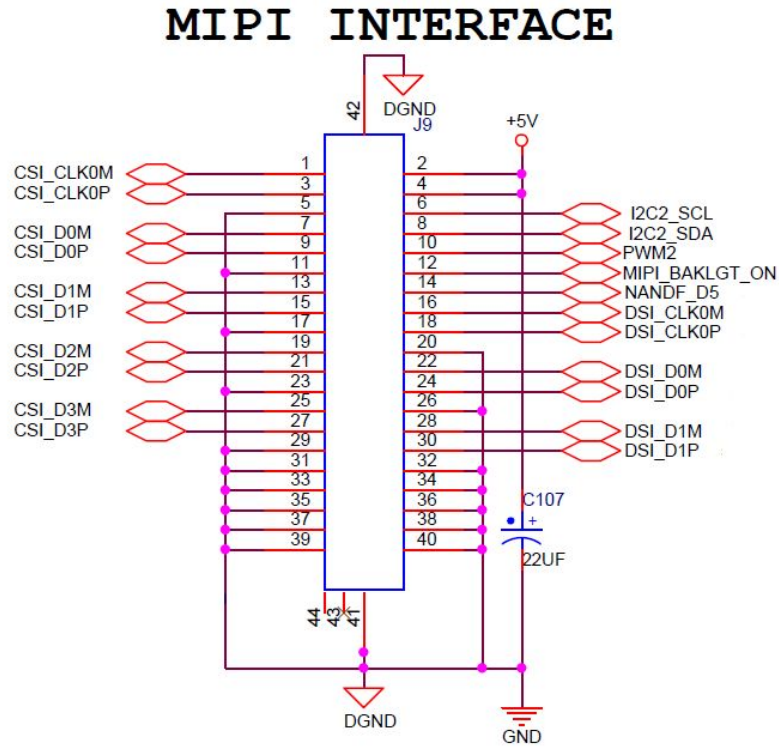

4.7 Expansion Connector

J20 connector is reserved for future expansion:

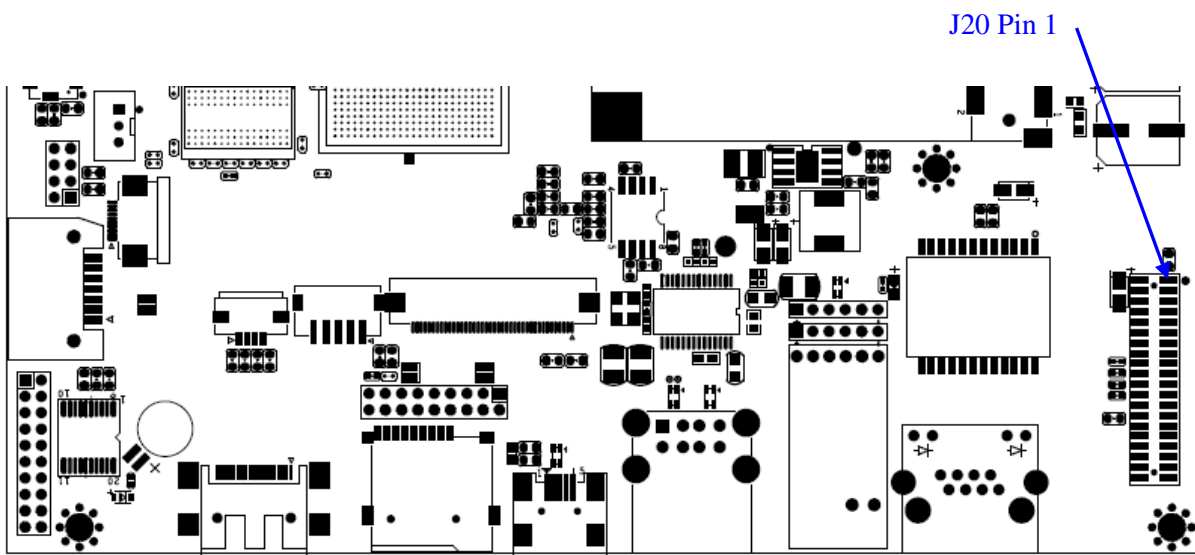
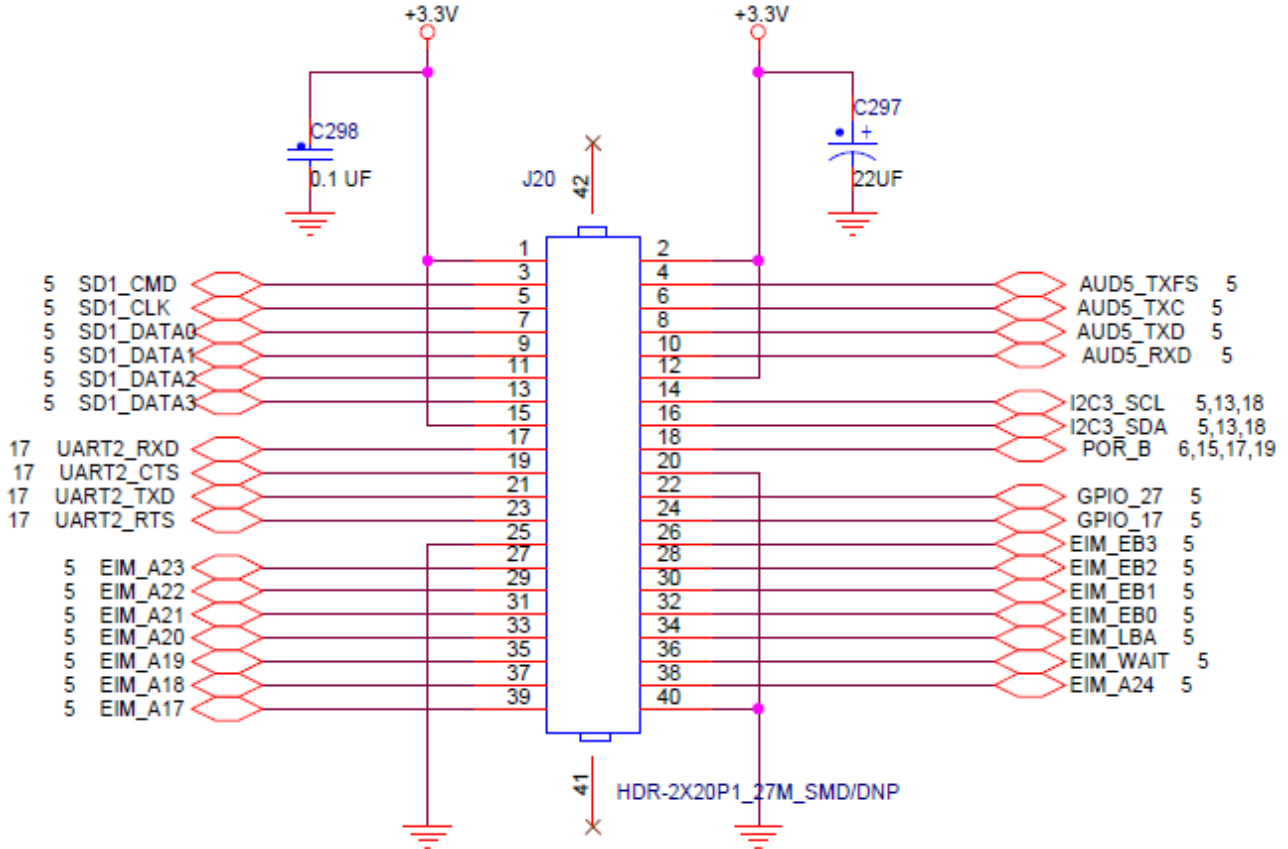

4.8 Keypad Connector

SW1 connector can be used in Android (or other OS) as keypad input.

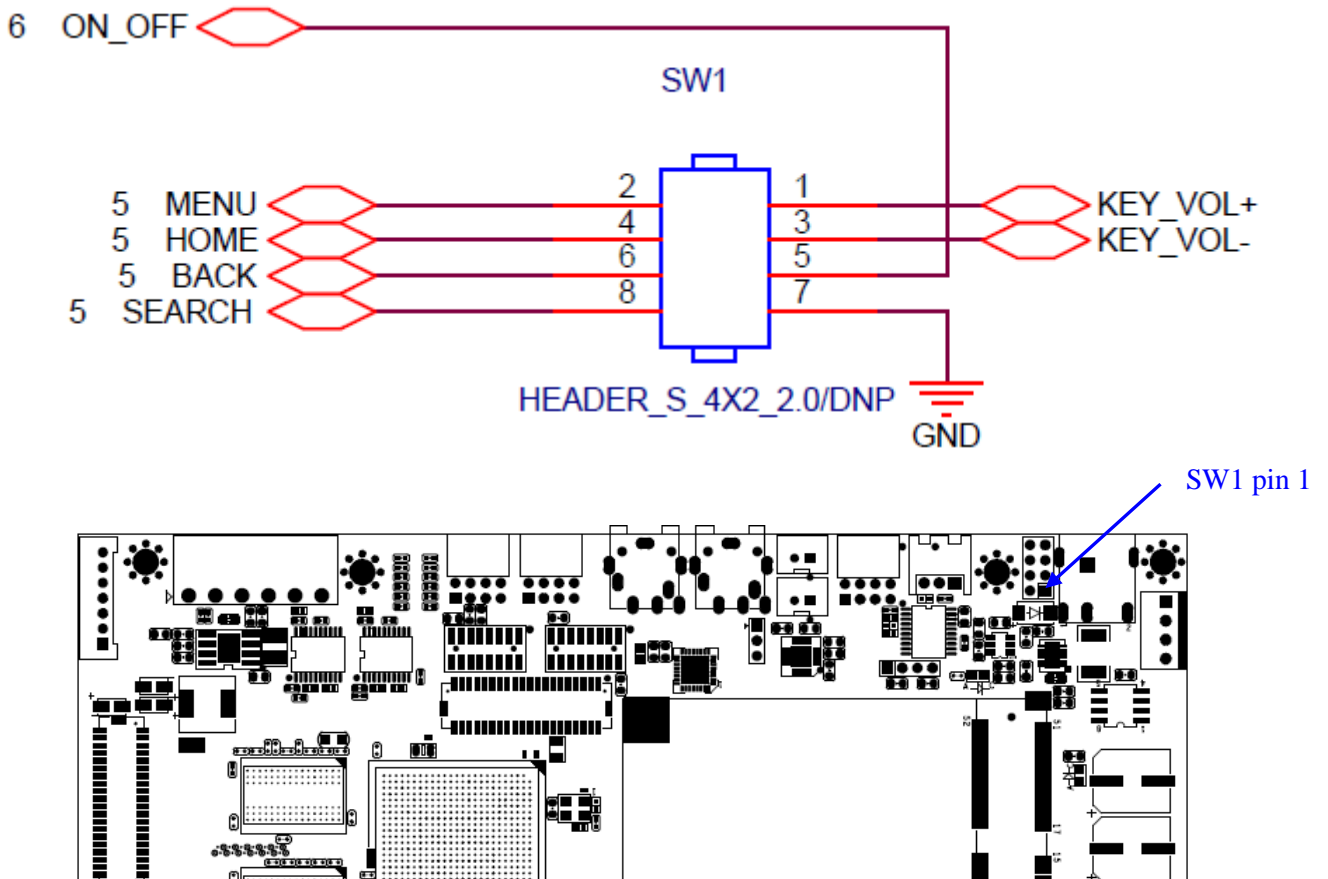

4.9 Mini-PCle Connector

The Mini-PCle connector J11 now supports only 3G (WCDMA) module.

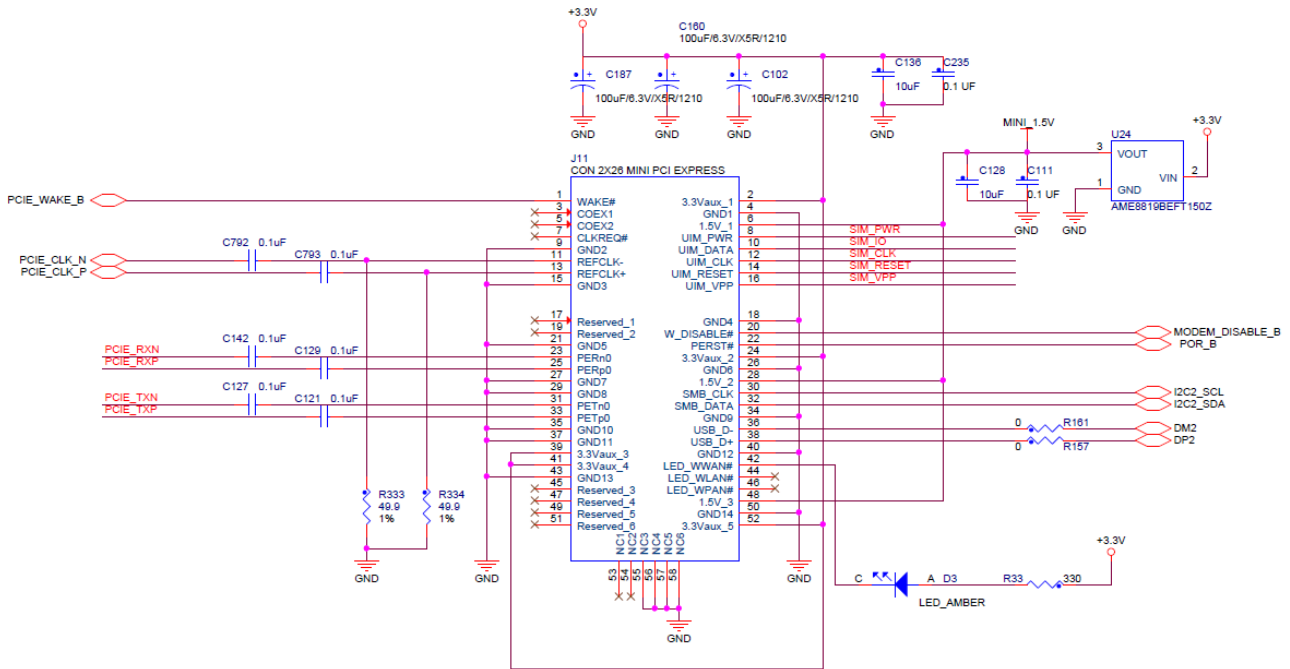

4.10 SATA Interface

The CN4 connector is an integrated Serial Advanced Technology Attachment (SATA) controller that is compatible with the Advanced Host Controller Interface (AHCI) specification.

- Compliant with the following specifications:
 - Serial ATA 2.0
 - AHCI Revision 1.3
- SATA 1.5 Gb/s and SATA 3.0 Gb/s speed

Pin	Signal	Pin	Signal
1	GND	5	Data B-
2	Data A+	6	Data B+
3	Data A-	7	GND
4	GND		

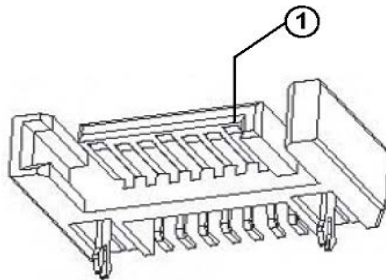

5 SBC2100 PCB Outline Drawing

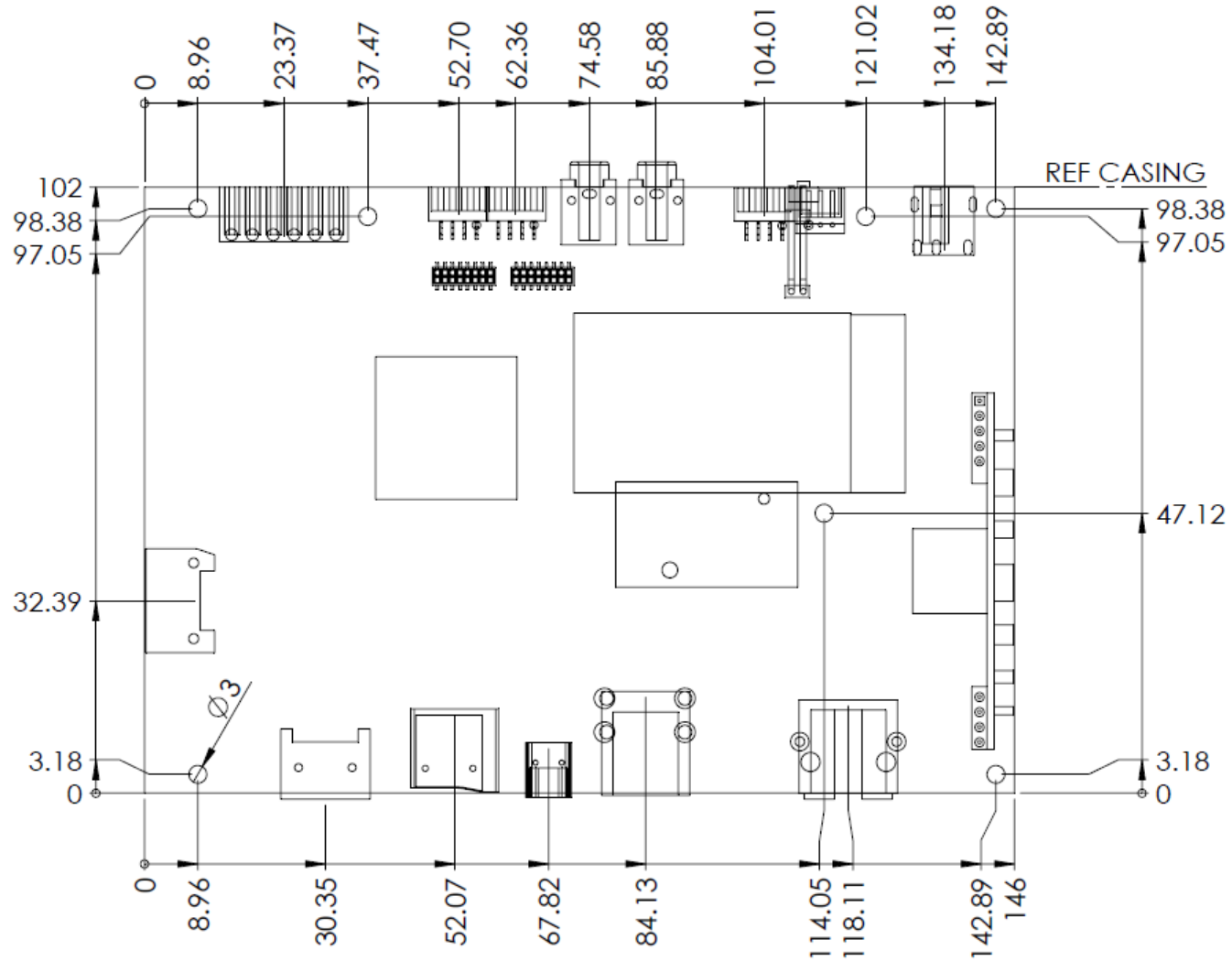

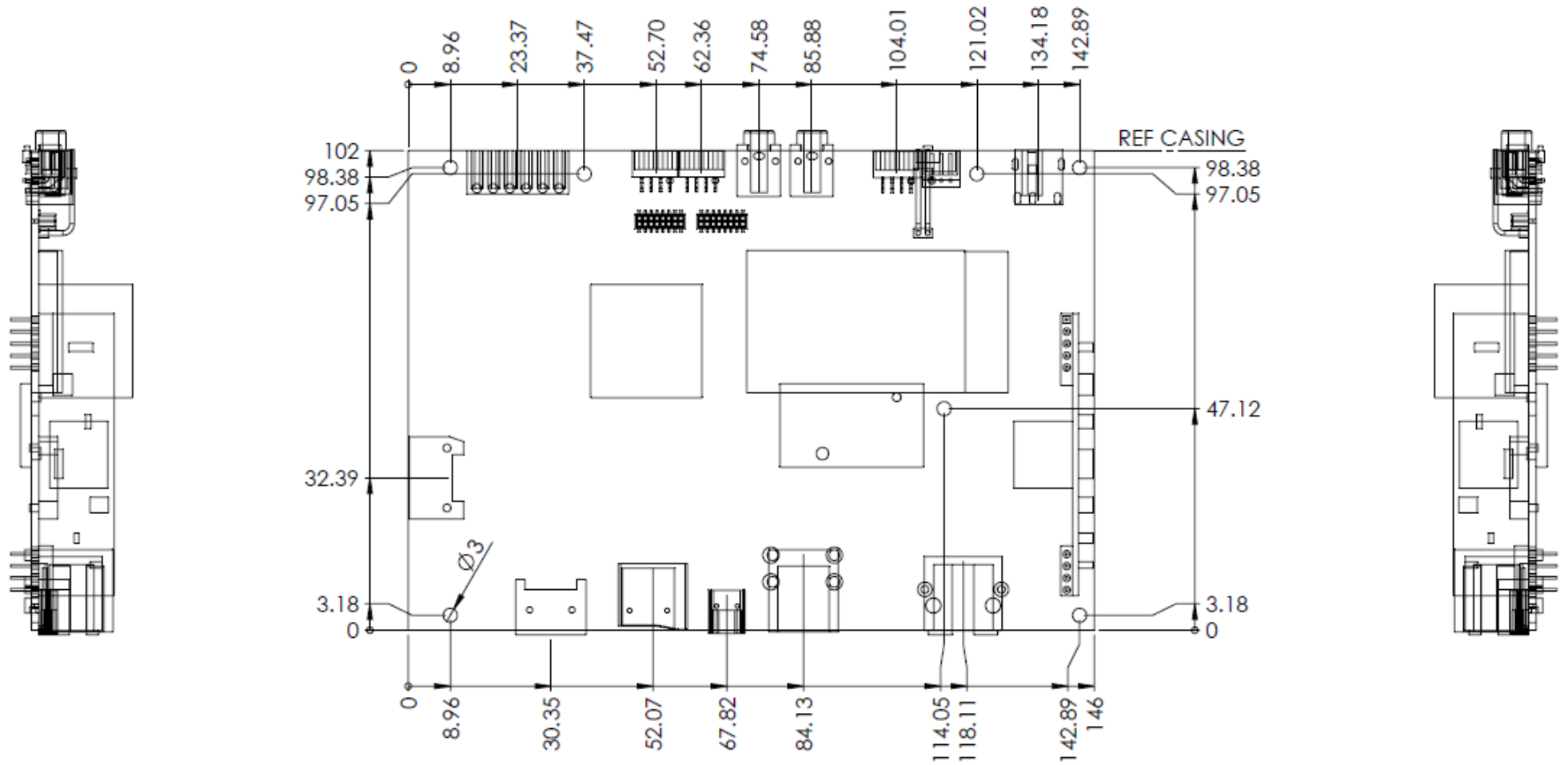

Appendix A: Box Header to DB9 Cable

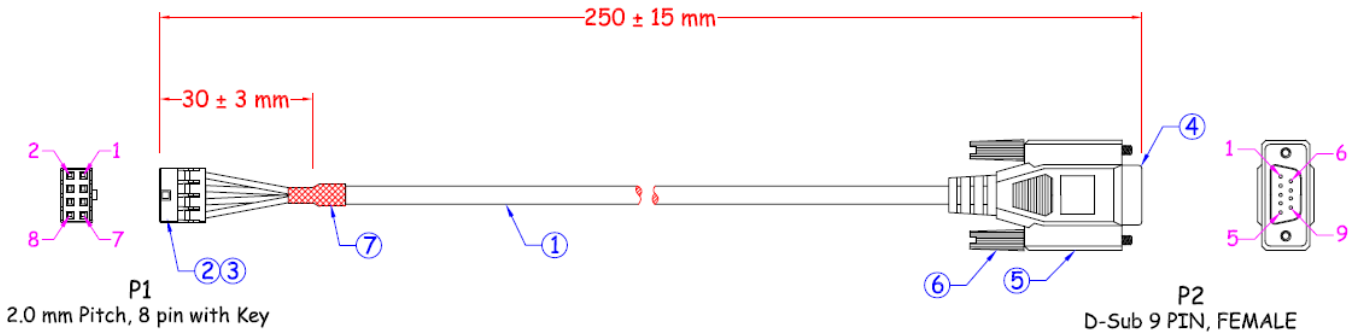

WIRE TERMINATIONS

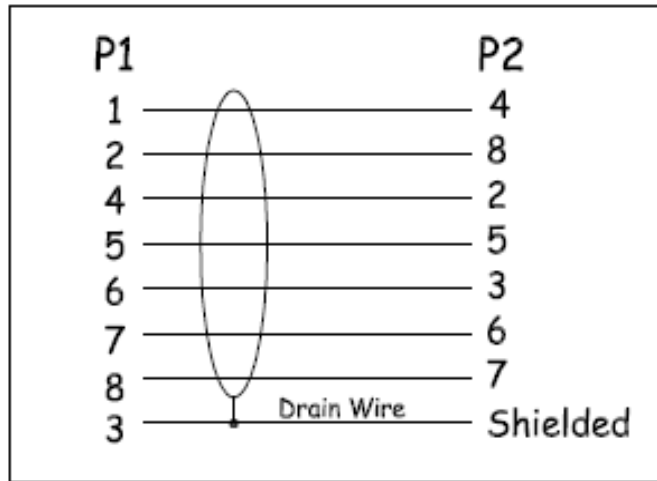

Appendix B: 7-inch LCD Brief (WVGA)

General Features:

The 7-inch LCD panel is a transmissive type color active matrix TFT (Thin Film Transistor) liquid crystal display (LCD) that uses amorphous silicon TFT as a switching device. This model is composed of a TFT-LCD module, a driver circuit, touch panel, and a backlight unit. Graphics and texts can be displayed on a WVGA 800 (W) x 3 x 480 (H) dots (16:9 aspect ratio) with 262,144 colors by supplying 18 bits data signal (6 bits for each color).

LCD Module Features

- Transmissive and back-light with 24 LEDs available
- TN (Twisted Nematic) mode
- Digital RGB (6bits/color) data transfer
- Data enable mode
- Back-light dimming control

LCD Module Specifications

Item	Specification	Unit
Screen Size	7.0 inches	Diagonal
Display Resolution	800 (H) x 480 (V)	Pixel
Active Area	154.08 (H) x 85.92 (V)	mm
Outline Dimension	165.00 (H) x 104.00 (V) x 6.55 (T)	mm
Display Mode	Normally white mode	--
Surface Treatment	Anti-glare(AG)	--
Pixel Arrangement	RGB Vertical Stripe	--
Pixel Size	190.5 x 190.5	um
Display Color	262K	--
Input Interface	Digital RGB (6bits/color) Data Transfer	--

Mechanical Data

Item		Value	Unit	Notes
Module Size	Horizontal (H)	165.00	mm	
	Vertical (V)	104.00	mm	
	Thickness (T)	6.55	mm	(1)
Weight		TBD	g	--

Note (1) Not Include Component

Environmental Rating

Item	Symbol	Min	Max	Unit
Storage Temperature	T _{STG}	-30	80	°C
Operating Temperature	T _{OPR}	-20	70	°C

Optical Characteristics

Item	Symbol	Value	Unit
Brightness	B	300	cd/m ²
Contrast Ratio	CR	250	--

Appendix C: 7-inch LCD Brief (WSVGA)

General Features:

The 7-inch LCD panel is a transmissive type color active matrix TFT (Thin Film Transistor) liquid crystal display (LCD) that uses amorphous silicon TFT as a switching device. This model is composed of a TFT-LCD module, a driver circuit, touch panel and backlight unit. Graphics and texts can be displayed on a XGA 1024 (W) x RGB x 600 (H) dots with 16.7M colors by supplying 24 bits data signal (8 bits for each color).

LCD Module Features:

- Transmissive and back-light with 18 LEDs available
- Digital RGB (8 bits / color) data transfer
- ROHS Compliant

LCD Module Specifications

Item	Specification	Unit
Screen Size	7.0 inches	Diagonal
Display Resolution	1024 (H) x 600 (V)	Pixel
Active Area	153.6 (H) x 90.0 (V)	mm
Outline Dimension	165.75 (H) x 105.39 (V) x 3.40 (T)	mm
Display Mode	Normally white mode	--
Surface Treatment	Anti-glare (AG)	--
Pixel Arrangement	RGB Vertical Stripe	--
Pixel Size	0.150 x 0.150	mm
Display Color	16.7M	--
Input Interface	Digital RGB (8 bits/color) Data Transfer	--

Mechanical Data

Item		Value	Unit	Notes
Module Size	Horizontal (H)	165.75	mm	
	Vertical (V)	105.39	mm	
	Thickness (T)	3.40	mm	(1)
Weight		TBD	g	--

Note (1) Not Include Component

Environment Rating

Item	Symbol	Min	Max	Unit
Storage Temperature	T _{STG}	-30	70	°C
Operating Temperature	T _{OPR}	-20	60	°C

Optical Characteristics

Item	Symbol	Min	Typical	Unit
Brightness	B	350	400	cd/m ²
Contrast Ratio	CR	400	500	--

Appendix D: 10.1-inch LCD Brief

General Features:

The 10.1-inch LCD panel is a transmissive type color active matrix TFT (Thin Film Transistor) liquid crystal display (LCD). This model is composed of a TFT-LCD module, a driver circuit, touch panel and a back-light unit. The resolution of a 10.1" contains 1280 (W) x RGB x 800 (H) dots and can display up to 16.7M colors.

LCD Module Features:

- Transmissive and back-light with LEDs available
- One channel LVDS interface
- ROHS Compliant

LCD Module Specifications:

Item	Specification	Unit
Screen Size	10.1 inches	Diagonal
Display Resolution	1280 x RGB x 800	Pixel
Active Area	216.96 (H) x 135.6 (V)	mm
Outline Dimension	227.7 (H) x 147.8 (V) x 4.6 (D)	mm
Display Mode	Normally white mode	--
Pixel Arrangement	RGB Stripe	--
Pixel Size	0.1695 x 0.1695	mm
Display Color	16.7M	--
Surface Treatment	Anti-Glare	
Input Interface	LVDS Interface	--

Environmental Rating

Item	Symbol	Min	Max	Unit
Storage Temperature	T _{STG}	-20	60	°C
Operating Temperature	T _{OPR}	0	50	°C

Optical Characteristics

Item	Symbol	Min	Typical	Unit
Brightness	--	280	350	cd/m ²
Contrast Ratio	CR	800	--	--

Appendix E: 15-inch LCD Brief

General Features:

The 15-inch LCD panel is a transmissive type color active matrix TFT (Thin Film Transistor) liquid crystal display (LCD) that uses amorphous silicon TFT as a switching device. This model is composed of a TFT-LCD module, a driver circuit, touch panel and a back-light unit. The resolution of a 15" contains 1024 (W) x RGB x 768 (H) dots and can display up to 16.2M colors.

LCD Module Features:

- Transmissive and back-light with LEDs available
- One channel LVDS interface
- ROHS Compliant

LCD Module Specifications:

Item	Specification	Unit
Screen Size	15 inches	Diagonal
Display Resolution	1024 x RGB x 768	Pixel
Active Area	304.128 (H) x 228.096 (V)	mm
Outline Dimension	326.5 (H) x 253.5.2 (V) x 12.0 (D)	mm
Display Mode	Normally white mode	--
Pixel Arrangement	RGB Vertical Stripe	--
Pixel Size	0.297 x 0.297	mm
Display Color	16.2M	--
Surface Treatment	Anti-Glare	
Input Interface	LVDS Interface	--

Mechanical Data

Item		Typical	Max	Unit
Module Size	Horizontal (H)	326.50	--	mm
	Vertical (V)	253.50	--	mm
	Thickness (T)	12.00	--	mm
Weight		930	960	g

Environment Rating

Item	Symbol	Min	Max	Unit
Storage Temperature	T _{STG}	-30	80	°C
Operating Temperature	T _{OPR}	-20	70	°C

Optical Characteristics

Item	Symbol	Min	Typical	Unit
White Brightness	--	--	350	cd/m ²
Contrast Ratio	CR	450	800	--

Appendix F: 15-inch LCD Brief (High Brightness)

General Features:

The 15-inch LCD panel is a transmissive type color active matrix TFT (Thin Film Transistor) liquid crystal display (LCD) that uses amorphous silicon TFT as a switching device. This model is composed of a TFT-LCD module, a driver circuit, touch panel and a back-light unit. The resolution of a 15" contains 1024 (W) x RGB x 768 (H) dots and can display up to 16.2M colors.

LCD Module Features:

- Transmissive and back-light with LEDs available
- TN (Twisted Nematic) mode
- One channel LVDS interface
- ROHS Compliant

LCD Module Specifications:

Item	Specification	Unit
Screen Size	15 inches	Diagonal
Display Resolution	1024 x RGB x 768	Pixel
Active Area	304.128 (H) x 228.096 (V)	mm
Outline Dimension	326.5 (H) x 253.5.2 (V) x 14.3 (D)	mm
Display Mode	Normally white mode	--
Pixel Arrangement	RGB Vertical Stripe	--
Pixel Size	0.297 x 0.297	mm
Display Color	16.2M / 262K	--
Surface Treatment	Anti-Glare	
Input Interface	LVDS Interface	--

Environmental Rating

Item	Symbol	Min	Max	Unit
Storage Temperature	T _{STG}	-30	85	°C
Operating Temperature	T _{OPR}	-30	85	°C

Optical Characteristics

Item	Symbol	Min	Typical	Units
White Brightness	--	960	1200	cd/m ²
Contrast Ratio	CR	400	700	--

Appendix G: 21.5-inch LCD Brief

General Features:

The 21.5-inch LCD panel is a transmissive type color active matrix TFT (Thin Film Transistor) liquid crystal display (LCD) that uses amorphous silicon TFT as a switching device. This model is composed of a TFT-LCD module, a driver circuit, touch panel and a back-light unit. The resolution of a 21.5" contains 1920 (W) x RGB x 1080 (H) dots and can display up to 16.7M (RGB 6-bit + Hi_FRC) colors.

LCD Module Features:

- Transmissive and back-light with LEDs available
- TN (Twisted Nematic) mode
- Dual channel LVDS interface
- ROHS Compliant

LCD Module Specifications:

Item	Specification	Unit
Screen Size	21.5 inches	Diagonal
Display Resolution	1920 x RGB x 1080	Pixel
Active Area	476.64 (H) x 268.11 (V)	mm
Outline Dimension	-- (H) x -- (V) x -- (D)	mm
Display Mode	Normally white mode	--
Pixel Arrangement	RGB Vertical Stripe	--
Pixel Size	0.248 x 0.248	mm
Display Color	16.7M (RGB 6-bit + Hi_FRC)	--
Surface Treatment	Anti-Glare	
Input Interface	LVDS Interface	--

Environmental Rating

Item	Symbol	Min	Max	Units
Storage Temperature	T _{STG}	0	50	°C
Operating Temperature	T _{OPR}	-20	60	°C

Optical Characteristics

Item	Symbol	Min	Typical	Units	Notes
White Brightness	--	1000	1200	cd/m ²	(1)
White Brightness	--	300	350	cd/m ²	(2)
Contrast Ratio	CR	600	1000	--	

(1) High Brightness

(2) Standard Brightness